

FS-H Float Switch for Horizontal Mounting

For use with non-corrosive liquids, 30W

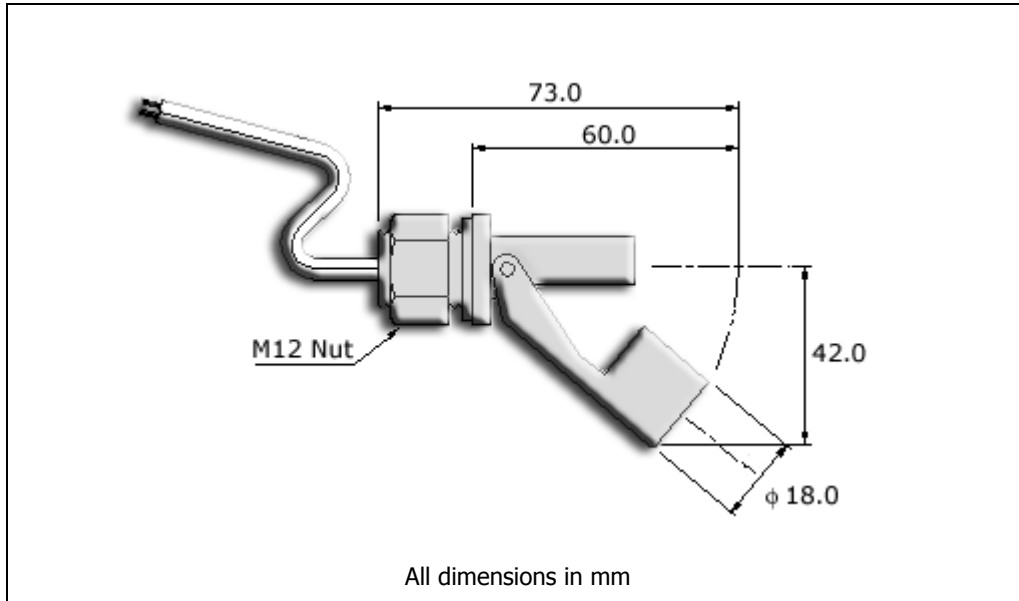

- ◆ Normally open (NO) contact
- ◆ Different on and off levels angles
- ◆ Does not require power for operation
- ◆ Various types of leads and connectors available
- ◆ Contact rating of up to 30W
- ◆ Lead (Pb) free and RoHS compliant

🔧 Applications

This magnet sensor is suitable for use in the following applications and in many others: domestic coffee machines, automatic pump control...

📊 Specification

Contact Form		A
Contact Rating (max)	W / VA	30
Switching Current (max)	A	0.5
Carry Current (max)	A	2.5
Switching Voltage (max)	V _{DC / AC}	230
Breakdown Voltage (min)	V _{DC}	350
Initial Contact Resistance (max)	mΩ	150
Operating Temperature	°C	-40 to +70
Shock Resistance (½Sin wave for 11ms)	g	50
Vibration Resistance (10-2000Hz)	g	20

📦 Ordering Code

FS-H-(Cable Length in mm)-(Lead Type)

Lead Type
S. Stripped to 5 mm
T. Stripped to 5 mm and Tinned
M. Molex Connector

🔪 Example

FS-H-500-M

Denotes normally open FS-H Float switch with 500 mm cable length and Molex connectors.

Due to continual improvement, specifications are subject to change without notice

www.reed-sensor.com

15 March 2008