

Reed Sensors

◆ Surface Mount Devices ◆

◆ Normally Open ◆

◆ Normally Closed ◆

◆ Integrated Resistor ◆

◆ PCB Mountable ◆

◆ Wattage Configurable ◆

RREE



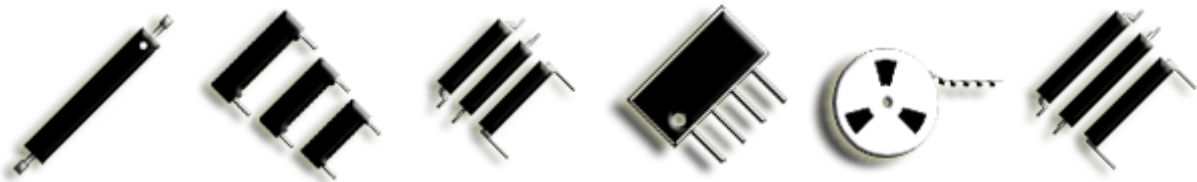



www.reed-sensor.com



SMD Reed Sensors

Contents

We manufacture a range of SMD, and PCB mountable reed sensors in normally-open, normally closed, change over, and latching types. The SMD versions are supplied in tapes conforming to IEC 60286-3 standards, for automatic pick and place, and can be used in assemblies where all the components are SMD. Omni-polar PCB mountable reed sensors come in a range of sizes and mounting pitches, capable of switching the lowest of 1W loads, up to 30 W. In addition, molded PCB mountable reed sensors with an integrated resistor are available. The integrated resistor can be used for level sensing applications, contact protection, or custom diagnostics.

	<p>R5-J Ultra-miniature J-Lead Reed Sensors Omni polar, normally open (NO), 7.5 mm SMD pitch. 5W switching capability at 0.35 A current, internal blades are oriented to top surface of sensor.</p>
	<p>R5-S Ultra-miniature SMD Reed Sensors Omni polar, normally open (NO), 9.5 mm SMD pitch. 5W switching capability at 0.35 A current, internal blades are oriented to top surface of sensor.</p>
	<p>R3 Miniature SMD Reed Sensors Omni polar, normally open (NO), 16.25 mm SMD and low-profile SMD pitch. 10 W switching capability at 0.5 A current, internal blades are oriented to top surface of sensor.</p>
	<p>R2 Standard size SMD Reed Sensors Omni polar, normally open (NO), 19.5 mm SMD and low-profile SMD pitch, 10 W switching capability at 0.5 A switching and 1.5 A carry, internal blades are oriented to top surface of sensor.</p>
 Form B	<p>R2B Normally Closed SMD Reed Sensors Polarity sensitive, normally closed (NC), 19.5 mm SMD and low-profile SMD pitch. 10W switching capability at 0.5 A, internal blades are oriented to top surface of sensor.</p>
 Form E	<p>R2E Latching / Bi-stable SMD Reed Sensors Polarity sensitive, "remembers" last actuated state, 19.5 mm SMD and low-profile SMD pitch, capable of switching 10 W at 0.5 A, internal blades oriented to top surface of sensor.</p>





Due to continual improvement, specifications are subject to change without notice

www.reed-sensor.com

12 February 2007

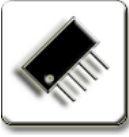
PCB Mountable Reed Sensors

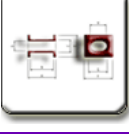
Contents

	<p>MK Reed sensor with integrated resistor Omni polar, normally open (NO), molded with internal blades perpendicular to dot marked surface, integrated 0.125 W resistor with a range of values. Suitable for level sensing.</p>
	<p>MS-10x Miniature PCB Mountable Reed Sensors Omni polar, normally open (NO), epoxy encapsulated, PCB mountable sensors in 10.6 mm, 12.7 mm, and 15.2 mm pitch, capable of switching up to 10W, internal blades oriented to top surface of sensor.</p>
	<p>MS-10x Standard Size PCB Mountable Reed Sensors Omni polar, normally open (NO), epoxy encapsulated, PCB mountable sensors in 17.7 mm, and 20.3 mm pitch, capable of switching up to 30W, internal blades oriented to top surface of sensor, change over versions available on request.</p>
	<p>Test Coils and Standard Magnets List of standard test coils used to measure reed switch and reed sensor operating parameters. All reed sensors we produce are measured in one of these coils...</p>
	<p>RoHS Compliance All reed switches are SGS certified for the RoHS compliant levels of Lead, Mercury, Cadmium and Hexalent Chromium.</p>

Due to continual improvement, specifications are subject to change without notice

www.reed-sensor.com

25 December 2006

R5-J Ultra-Miniature SMD Reed Sensor

J-Leads, Normally Open, 5W

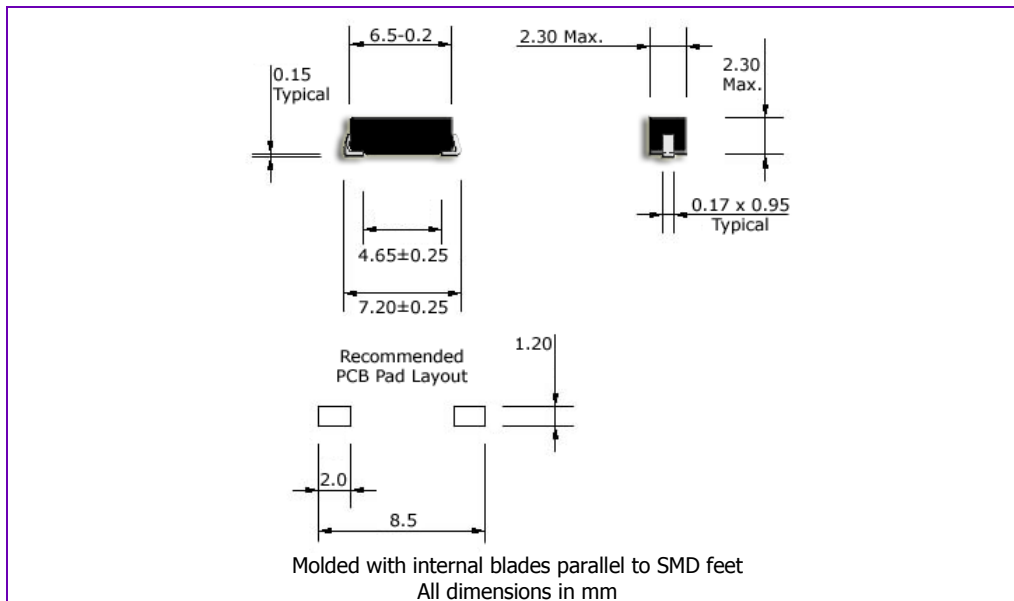

- ◆ Does not require power for operation
- ◆ Normally open (NO) form A contact
- ◆ Omni-polar device; actuates with either pole of magnet
- ◆ Molded with internal blades parallel to SMD feet
- ◆ Packed in tape and reels conforming to IEC-60286-3 norms
- ◆ Lead (Pb) free and RoHS compliant

Applications

This reed sensor is suitable for use in the following applications and many others: cellular phones and PDAs, dentist drills, pacemakers and defibrillators, nerve stimulators, spirometers, high resolution level sensors...

Specification

Contact Form		A
Contact Rating (max)	W / VA	5.0
Switching Current (max)	A	0.35
Carry Current (max)	A	0.5
Switching Voltage (max)	V _{DC}	100
Breakdown Voltage (min)	V _{DC}	150
Initial Contact Resistance (max)	mΩ	200
Operating Temperature	°C	-40 to +140
Shock Resistance (½Sin wave for 11ms)	g	30
Vibration Resistance (10-2000Hz)	g	20

Ordering Code

R5-J-(Operate AT Code)-(Packing Code)

OAT Code	*Before	*After	Packing Code	
1	7 - 12	15 - 40	L	Plastic Box (500)
2	12 - 17	30 - 50	G	Tape (2500)

*Indicate Operate AT band before and after modification of leads

Example

R5-J-1-G denotes 7-12 Operate AT packed in taped reels.

Due to continual improvement, specifications are subject to change without notice

www.reed-sensor.com

18 January 2008

R5-J Ultra-Miniature SMD Reed Sensor

Actuation Distances

Operate and release distances for the R5-J ultra-miniature reed sensor in two standard AT bands, when actuated (as shown in the sketches) with NdFeB standard magnets is shown below. All distances given are in mm with tolerances of ± 0.5 mm. Although some of the AT band / magnet combinations will produce similar actuating distances, selecting the right AT band and magnet for an application is important and can be done by going through our AT band FAQ and our magnet selection guide.

R5J-1 (7-12 AT)

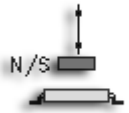
Actuation Sketch	Magnet	Dimensions	Operate Distance	Release Distance
	NDR-T	4.0 x 1.5 x 1.5	2.0 – 4.5	2.0 – 5.0
	NDC-T	Ø2.0 x 4.0	2.5 – 5.0	2.5 – 5.5
	NDR-S	6.0 x 2.5 x 2.5	5.0 – 8.0	5.0 – 8.5
	NDC-S	Ø3.0 x 7.0	5.5 – 9.0	5.5 – 9.5
	NDR-M	8.0 x 3.0 x 3.0	6.5 – 11.0	6.5 – 11.5
	NDC-M	Ø4.0 x 10.0	9.0 – 13.0	9.0 – 13.5
	NDR-L	19.0 x 4.0 x 4.0	11.5 – 18.5	11.5 – 19.0
	NDC-L	Ø8.0 x 15.0	18.0 – 26.0	18.0 – 26.5

R5J-2 (12-17 AT)

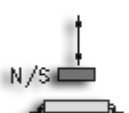
Actuation Sketch	Magnet	Dimensions	Operate Distance	Release Distance
	NDR-T	4.0 x 1.5 x 1.5	1.5 – 3.0	1.5 – 3.5
	NDC-T	Ø2.0 x 4.0	2.0 – 3.5	2.0 – 4.0
	NDR-S	6.0 x 2.5 x 2.5	4.5 – 6.0	4.5 – 6.5
	NDC-S	Ø3.0 x 7.0	5.0 – 7.0	5.0 – 7.5
	NDR-M	8.0 x 3.0 x 3.0	6.0 – 8.0	6.0 – 8.5
	NDC-M	Ø4.0 x 10.0	8.5 – 10.5	8.5 – 11.0
	NDR-L	19.0 x 4.0 x 4.0	10.5 – 13.0	10.5 – 13.5
	NDC-L	Ø8.0 x 15.0	17.0 – 21.0	17.0 – 21.5

Due to continual improvement, specifications are subject to change without notice

www.reed-sensor.com

31 July 2008

R5-J Packing

Tape and reel specifications

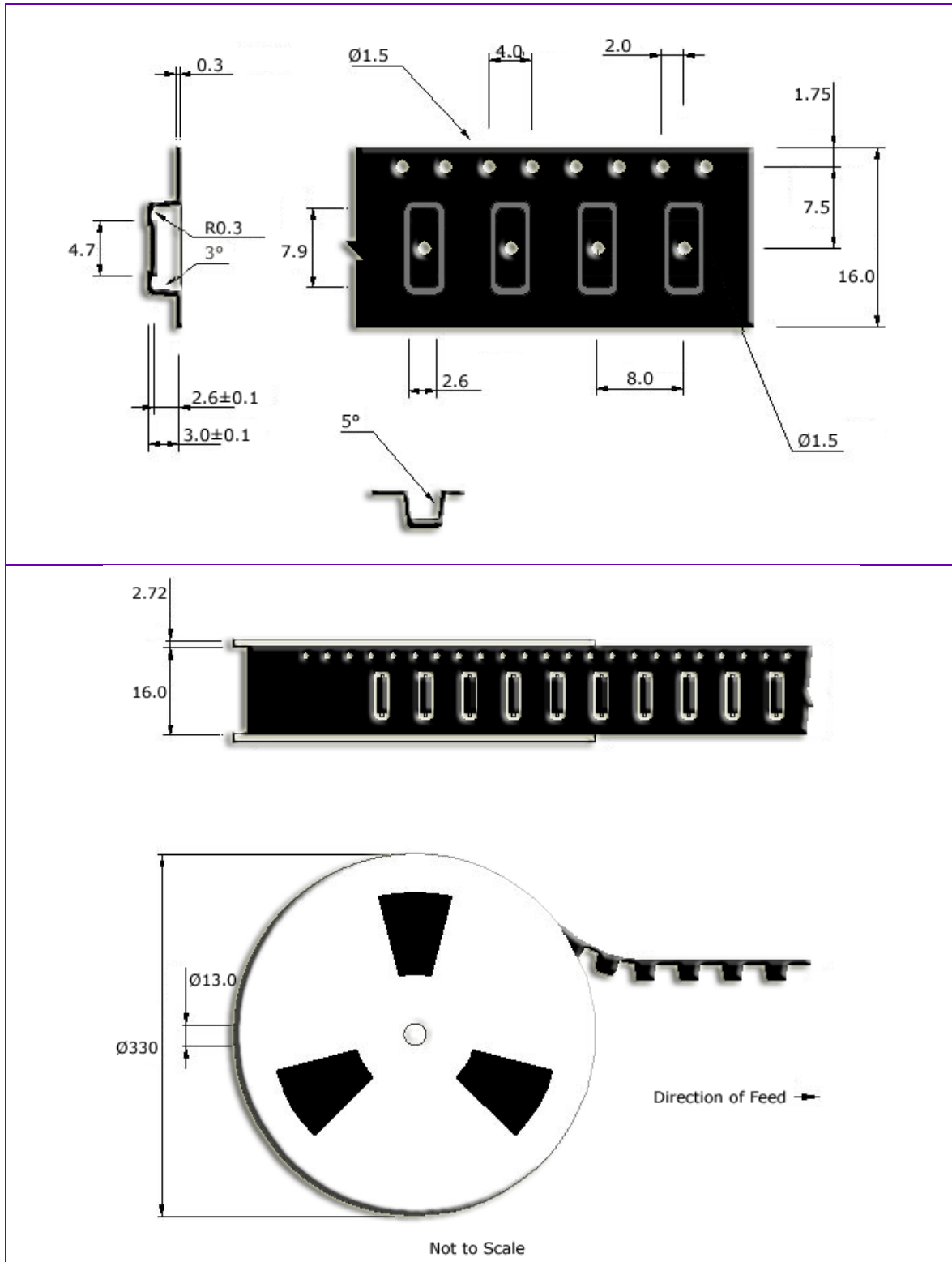

Tape and reel conform to IEC 60286-3 standards
40-80 g pull-force will be required to peel cover-tape
2500 sensors will be packed in one reel

Due to continual improvement, specifications are subject to change without notice

www.reed-sensor.com

25 December 2007

R5-S Ultra-Miniature SMD Reed Sensor

Gull wings, Normally Open, 5W

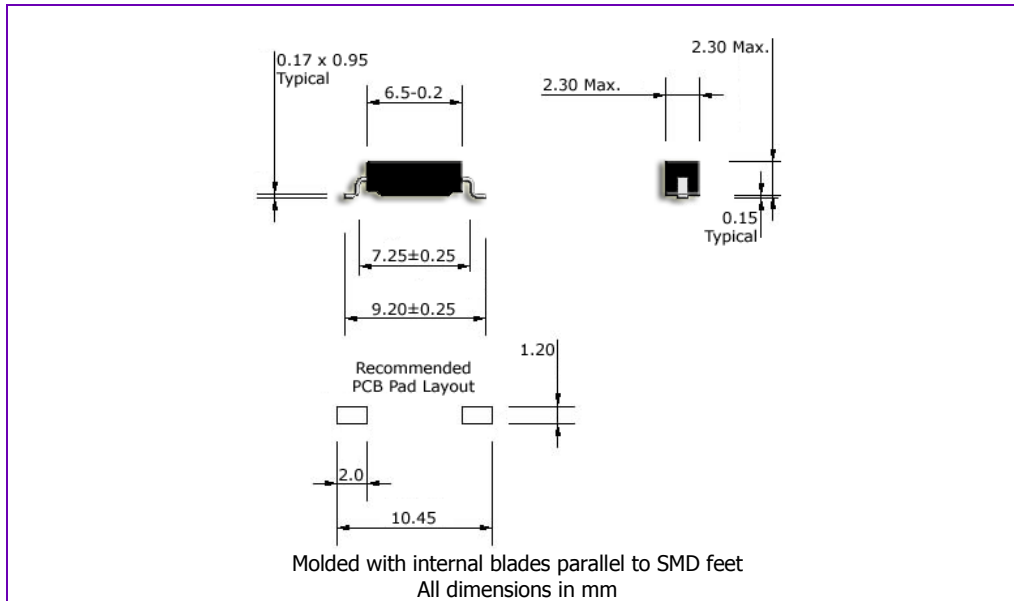

- ◆ Does not require power for operation
- ◆ Normally open (NO) form A contact
- ◆ Omni-polar device; actuates with either pole of magnet
- ◆ Molded with internal blades parallel to SMD feet
- ◆ Packed in tape and reels conforming to IEC-60286-3 norms
- ◆ Lead (Pb) free and RoHS compliant

Applications

This reed sensor is suitable for use in the following applications and many others: cellular phones and PDAs, dentists drills, pacemakers and defibrillators, nerve stimulators, spirometers, high resolution level sensors...

Specification

Contact Form		A
Contact Rating (max)	W / VA	5.0
Switching Current (max)	A	0.35
Carry Current (max)	A	0.5
Switching Voltage (max)	V _{DC}	100
Breakdown Voltage (min)	V _{DC}	150
Initial Contact Resistance (max)	mΩ	200
Operating Temperature	°C	-40 to +140
Shock Resistance (½Sin wave for 11ms)	g	30
Vibration Resistance (10-2000Hz)	g	20

Ordering Code

R5-S-(Operate AT Code)-(Packing Code)

OAT Code	*Before	*After	Packing Code	
1	7 - 12	15 - 35	L	Plastic Box (500)
2	12 - 17	25 - 45	G	Tape (2500)

*Indicate Operate AT band before and after modification of leads

Example

R5-S-1-G denotes 7-12 Operate AT packed in taped reels.

Due to continual improvement, specifications are subject to change without notice

www.reed-sensor.com

1 February 2008

R5-S Ultra-Miniature SMD Reed Sensor

Actuation Distances

Operate and release distances for the R5-S ultra-miniature reed sensor in two standard AT bands, when actuated (as shown in the sketches) with NdFeB standard magnets is shown below. All distances given are in mm with tolerances of ± 0.5 mm. Although some of the AT band / magnet combinations will produce similar actuating distances, selecting the right AT band and magnet for an application is important and can be done by going through our AT band FAQ and our magnet selection guide.

R5S-1 (7-12 AT)

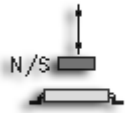
Actuation Sketch	Magnet	Dimensions	Operate Distance	Release Distance
	NDR-T	4.0 x 1.5 x 1.5	2.0 – 4.5	2.0 – 5.0
	NDC-T	Ø2.0 x 4.0	2.5 – 5.0	2.5 – 5.5
	NDR-S	6.0 x 2.5 x 2.5	5.0 – 8.5	5.0 – 9.0
	NDC-S	Ø3.0 x 7.0	6.0 – 10.0	6.0 – 10.5
	NDR-M	8.0 x 3.0 x 3.0	7.0 – 11.0	7.0 – 11.5
	NDC-M	Ø4.0 x 10.0	9.5 – 13.0	9.5 – 13.5
	NDR-L	19.0 x 4.0 x 4.0	11.5 – 19.0	11.5 – 19.5
	NDC-L	Ø8.0 x 15.0	19.0 – 27.0	19.0 – 27.5

R5S-2 (12-17 AT)

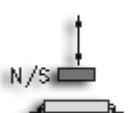
Actuation Sketch	Magnet	Dimensions	Operate Distance	Release Distance
	NDR-T	4.0 x 1.5 x 1.5	2.0 – 3.0	2.0 – 3.5
	NDC-T	Ø2.0 x 4.0	2.5 – 3.5	2.5 – 4.0
	NDR-S	6.0 x 2.5 x 2.5	5.0 – 6.5	5.0 – 7.0
	NDC-S	Ø3.0 x 7.0	5.5 – 7.5	5.5 – 8.0
	NDR-M	8.0 x 3.0 x 3.0	7.0 – 9.0	7.0 – 9.5
	NDC-M	Ø4.0 x 10.0	9.0 – 11.0	9.0 – 11.5
	NDR-L	19.0 x 4.0 x 4.0	11.0 – 15.0	11.0 – 15.5
	NDC-L	Ø8.0 x 15.0	17.5 – 22.0	17.5 – 22.5

Due to continual improvement, specifications are subject to change without notice

www.reed-sensor.com

31 July 2008

R5-S Packing

Tape and reel specifications

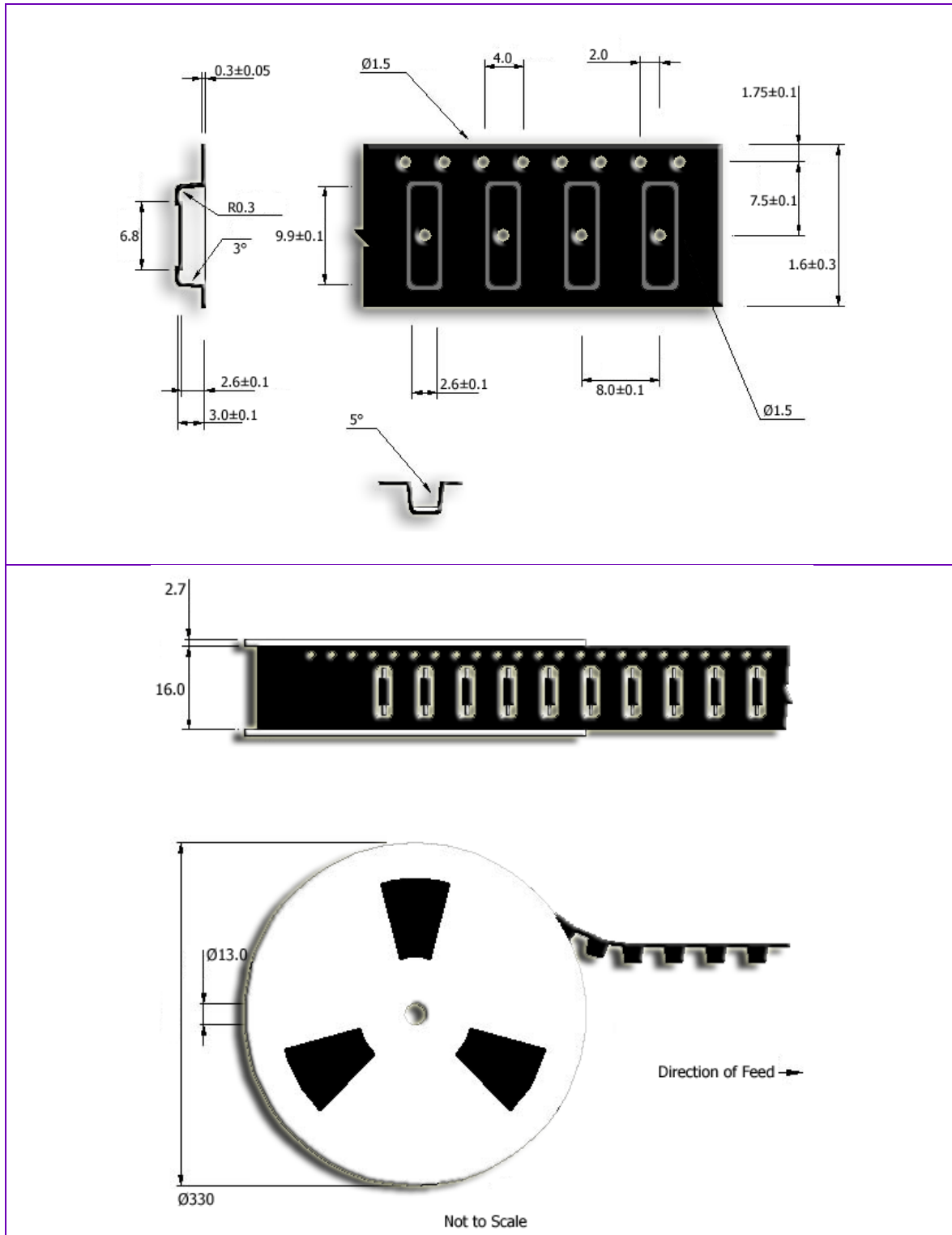

Tape and reel conform to IEC 60286-3 standards
40-80 g pull-force will be required to peel cover-tape
2500 sensors will be packed in one reel

Due to continual improvement, specifications are subject to change without notice

www.reed-sensor.com

14 July 2005

R3-S Miniature SMD Reed Sensor

Normally Open, 10W

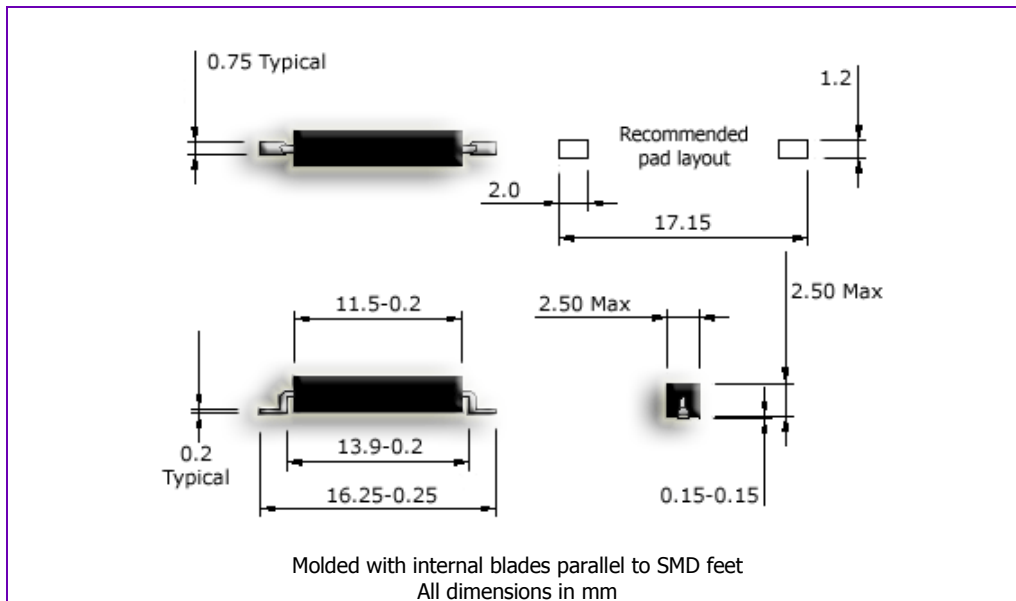

- ◆ Does not require power for operation
- ◆ Normally open (NO) form A contact
- ◆ Omni-polar device; actuates with either pole of magnet
- ◆ Molded with internal blades parallel to SMD feet
- ◆ Packed in tape and reels conforming to IEC-60286-3 norms
- ◆ Lead (Pb) free and RoHS compliant

Applications

This reed sensor is suitable for use in the following applications and many others: cellular phones and PDAs, weather proof electronics, electric tooth brushes, automobiles with electronic keys, digital pressure gauges, wind vanes, survival rafts and ELTs, pedometers, model gliders...

Specification

Contact Form		A
Contact Rating (max)	W / VA	10.0
Switching Current (max)	A	0.5
Carry Current (max)	A	0.75
Switching Voltage (max)	V _{DC}	100
Breakdown Voltage (min)	V _{DC}	150
Initial Contact Resistance (max)	mΩ	150
Operating Temperature	°C	-40 to +140
Shock Resistance (1/2Sin wave for 11ms)	g	30
Vibration Resistance (10-2000Hz)	g	20

Ordering Code

R3-S-(Operate AT Code)-(Packing Code)

OAT Code	*Before	*After	Packing Code	
1	10 – 15	18 – 31	L	Plastic Box (500)
2	15 – 20	28 – 41	G	Tape (2500)
3	20 – 25	38 – 51		

*Indicate Operate AT band before and after modification of leads

Example

R3-S-3-G denotes 20-25 Operate AT packed in taped reels.

Due to continual improvement, specifications are subject to change without notice

www.reed-sensor.com

1 February 2008

R3-S Miniature SMD Reed Sensor

Actuation Distances

Operate and release distances for the R3-S ultra-miniature reed sensor in two standard AT bands, when actuated (as shown in the sketches) with NdFeB standard magnets is shown below. All distances given are in mm with tolerances of ± 0.5 mm. Although some of the AT band / magnet combinations will produce similar actuating distances, selecting the right AT band and magnet for an application is important and can be done by going through our AT band FAQ and our magnet selection guide.

R3S-1 (10-15 AT)

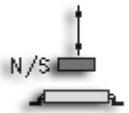
Actuation Sketch	Magnet	Dimensions	Operate Distance	Release Distance
	NDR-T	4.0 x 1.5 x 1.5	2.5 - 4.5	3.0 - 5.0
	NDC-T	Ø2.0 x 4.0	3.5 - 5.5	4.0 - 6.0
	NDR-S	6.0 x 2.5 x 2.5	6.5 - 9.5	7.0 - 10.0
	NDC-S	Ø3.0 x 7.0	8.0 - 10.5	9.0 - 11.0
	NDR-M	8.0 x 3.0 x 3.0	9.5 - 12.0	10.5 - 13.0
	NDC-M	Ø4.0 x 10.0	12.0 - 16.0	13.0 - 14.0
	NDR-L	19.0 x 4.0 x 4.0	17.0 - 21.5	18.0 - 23.0
	NDC-L	Ø8.0 x 15.0	25.0 - 32.5	27.0 - 33.5

R3S-2 (15-20 AT)

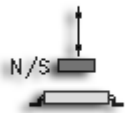
Actuation Sketch	Magnet	Dimensions	Operate Distance	Release Distance
	NDR-T	4.0 x 1.5 x 1.5	2.0 - 3.0	3.0 - 4.0
	NDC-T	Ø2.0 x 4.0	2.5 - 3.5	3.5 - 5.0
	NDR-S	6.0 x 2.5 x 2.5	5.5 - 7.0	6.5 - 8.5
	NDC-S	Ø3.0 x 7.0	6.5 - 8.5	8.0 - 10.0
	NDR-M	8.0 x 3.0 x 3.0	8.0 - 10.0	10.0 - 12.0
	NDC-M	Ø4.0 x 10.0	10.0 - 12.5	12.0 - 14.0
	NDR-L	19.0 x 4.0 x 4.0	14.0 - 17.5	17.0 - 21.0
	NDC-L	Ø8.0 x 15.0	22.0 - 26.0	25.5 - 30.0

R3S-3 (20-25 AT)

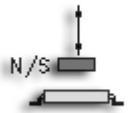
Actuation Sketch	Magnet	Dimensions	Operate Distance	Release Distance
	NDR-T	4.0 x 1.5 x 1.5	1.0 - 2.0	2.0 - 2.5
	NDC-T	Ø2.0 x 4.0	1.5 - 2.5	2.0 - 3.0
	NDR-S	6.0 x 2.5 x 2.5	4.5 - 6.0	6.0 - 8.0
	NDC-S	Ø3.0 x 7.0	5.5 - 7.0	7.0 - 8.5
	NDR-M	8.0 x 3.0 x 3.0	7.0 - 9.0	9.0 - 11.0
	NDC-M	Ø4.0 x 10.0	9.5 - 11.0	11.0 - 14.0
	NDR-L	19.0 x 4.0 x 4.0	12.5 - 16.0	16.0 - 19.0
	NDC-L	Ø8.0 x 15.0	20.0 - 23.0	23.0 - 27.0

Due to continual improvement, specifications are subject to change without notice

www.reed-sensor.com

31 July 2008

R3-F Miniature Low Profile SMD Reed Sensor

Low profile SMD Package, Normally Open

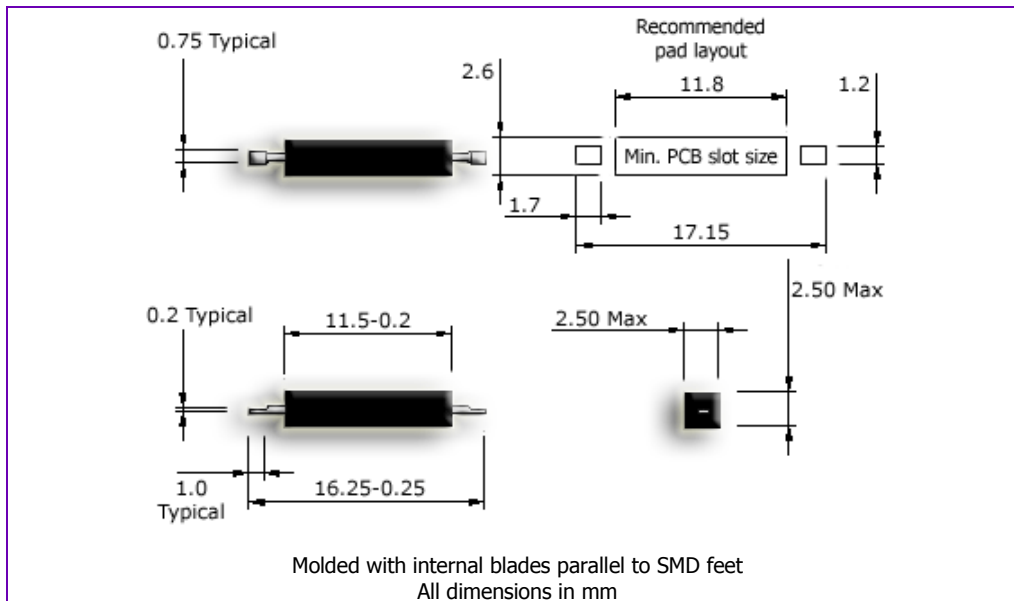

- ◆ Does not require power for operation
- ◆ Normally open (NO) form A contact
- ◆ Omni-polar device; actuates with either pole of magnet
- ◆ Molded with internal blades parallel to SMD feet
- ◆ Packed in tape and reels conforming to IEC-60286-3 norms
- ◆ Lead (Pb) free and RoHS compliant

Applications

This reed sensor is suitable for use in the following applications and many others: cellular phones and PDAs, weather proof electronics, electric tooth brushes, automobiles with electronic keys, digital pressure gauges, wind vanes, survival rafts and ELTs, pedometers, model gliders...

Specification

Contact Form		A
Contact Rating (max)	W / VA	10.0
Switching Current (max)	A	0.5
Carry Current (max)	A	0.75
Switching Voltage (max)	V _{DC}	100
Breakdown Voltage (min)	V _{DC}	150
Initial Contact Resistance (max)	mΩ	150
Operating Temperature	°C	-40 to +140
Shock Resistance (1/2Sin wave for 11ms)	g	30
Vibration Resistance (10-2000Hz)	g	20

Ordering Code

R3-F-(Operate AT Code)-(Packing Code)

OAT Code	*Before	*After	Packing Code	
1	10 – 15	18 – 31	L	Plastic Box (500)
2	15 – 20	28 – 41	G	Tape (2500)
3	20 – 25	38 – 51		

*Indicate Operate AT band before and after modification of leads

Example

R3-F-1-L denotes 10-15 operate AT packed in plastic boxes.

Due to continual improvement, specifications are subject to change without notice

www.reed-sensor.com

1 February 2008

R3-S and R3-F Packing

Tape and reel specifications

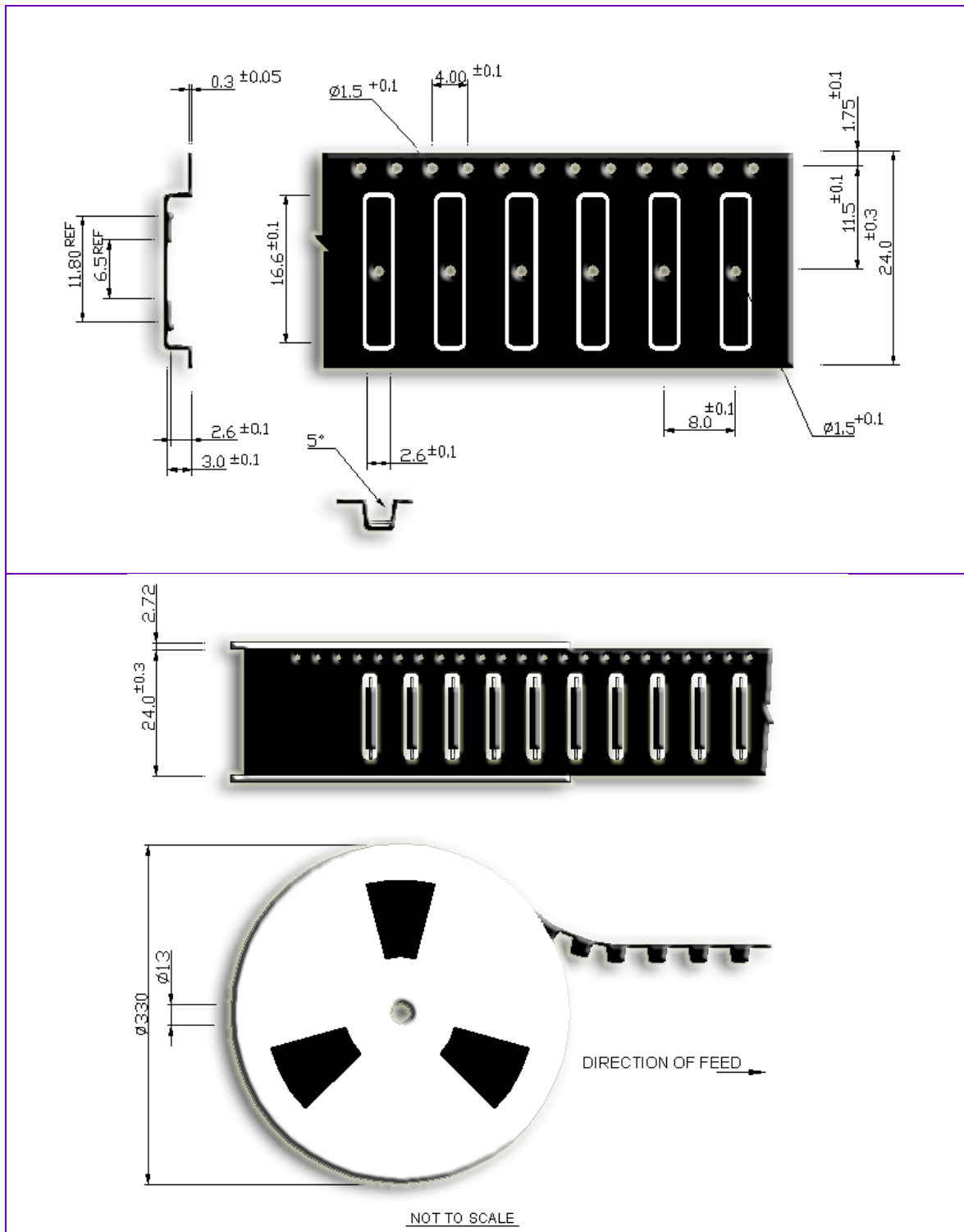

Tape and reel conform to IEC 60286-3 standards
40-80 g pull-force will be required to peel cover-tape
2500 sensors will be packed in one reel

Due to continual improvement, specifications are subject to change without notice

www.reed-sensor.com

6 December 2002

R2-S SMD Reed Sensor

SMD Package, Normally Open

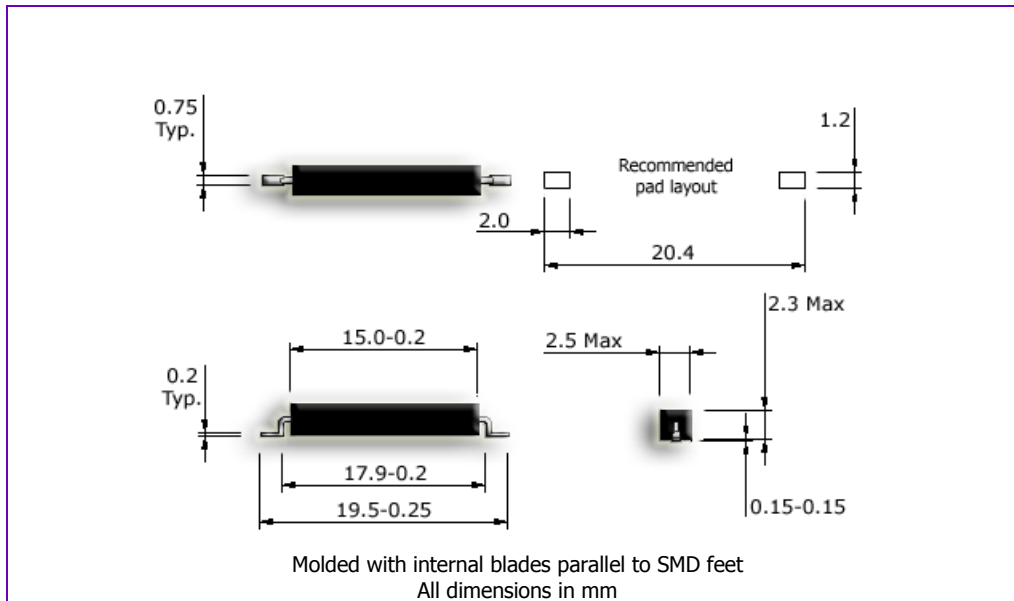

- ◆ Does not require power for operation
- ◆ Normally open (NO) form A contact
- ◆ Omni-polar device; actuates with either pole of magnet
- ◆ Molded with internal blades parallel to SMD feet
- ◆ Packed in tape and reels conforming to IEC-60286-3 norms
- ◆ Lead (Pb) free and RoHS compliant

🔧 Applications

This reed sensor is suitable for use in the following applications and many others: cellular phones and PDAs, weather proof electronics, fluid tank cap sensing, hands free kits...

📊 Specification

Contact Form		A
Contact Rating (max)	W / VA	10
Switching Current (max)	A	0.5
Carry Current (max)	A	1.5
Switching Voltage (max)	V _{DC}	180
Breakdown Voltage (min)	V _{DC}	200
Initial Contact Resistance (max)	mΩ	150
Operating Temperature	°C	-40 to +140
Shock Resistance (½Sin wave for 11ms)	g	30
Vibration Resistance (10-2000Hz)	g	20

📦 Ordering Code

R2-S-(Operate AT Code)-(Packing Code)

OAT Code	*Before	*After	Packing Code	
1	10 – 15	13 – 23	L	Plastic Box (500)
2	15 – 20	20 – 30	G	Tape (2500)
3	20 – 25	27 – 37		

*Indicate Operate AT band before and after modification of leads

🔧 Example

R2-S-3-L denotes 20-25 operate AT packed in plastic boxes.

Due to continual improvement, specifications are subject to change without notice

www.reed-sensor.com

1 February 2008

R2-S SMD Reed Sensor

Actuation Distances

Operate and release distances for the R2-S ultra-miniature reed sensor in two standard AT bands, when actuated (as shown in the sketches) with NdFeB standard magnets is shown below. All distances given are in mm with tolerances of ± 0.5 mm. Although some of the AT band / magnet combinations will produce similar actuating distances, selecting the right AT band and magnet for an application is important and can be done by going through our AT band FAQ and our magnet selection guide.

R2S-1 (10-15 AT)

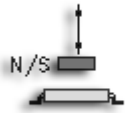
Actuation Sketch	Magnet	Dimensions	Operate Distance	Release Distance
	NDR-T	4.0 x 1.5 x 1.5	3.5 – 5.5	4.0 – 6.0
	NDC-T	Ø2.0 x 4.0	4.0 – 7.0	4.5 – 7.5
	NDR-S	6.0 x 2.5 x 2.5	8.0 – 11.5	9.0 – 12.0
	NDC-S	Ø3.0 x 7.0	9.5 – 13.5	10.5 – 14.0
	NDR-M	8.0 x 3.0 x 3.0	11.5 – 16.0	12.5 – 16.5
	NDC-M	Ø4.0 x 10.0	15.0 – 20.0	16.0 – 21.0
	NDR-L	19.0 x 4.0 x 4.0	20.0 – 26.5	22.0 – 27.0
	NDC-L	Ø8.0 x 15.0	30.0 – 39.5	32.5 – 40.5

R2S-2 (15-20 AT)

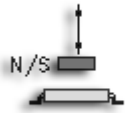
Actuation Sketch	Magnet	Dimensions	Operate Distance	Release Distance
	NDR-T	4.0 x 1.5 x 1.5	2.0 – 4.0	3.0 – 5.0
	NDC-T	Ø2.0 x 4.0	2.5 – 5.0	4.0 – 6.0
	NDR-S	6.0 x 2.5 x 2.5	6.5 – 9.0	7.5 – 10.5
	NDC-S	Ø3.0 x 7.0	8.0 – 10.5	9.5 – 12.0
	NDR-M	8.0 x 3.0 x 3.0	10.0 – 13.0	11.0 – 15.0
	NDC-M	Ø4.0 x 10.0	12.0 – 16.0	14.0 – 19.0
	NDR-L	19.0 x 4.0 x 4.0	17.5 – 22.0	20.0 – 25.0
	NDC-L	Ø8.0 x 15.0	26.0 – 32.0	29.0 – 35.0

R2S-3 (20-25 AT)

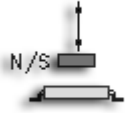
Actuation Sketch	Magnet	Dimensions	Operate Distance	Release Distance
	NDR-T	4.0 x 1.5 x 1.5	2.0 – 3.0	2.5 – 4.0
	NDC-T	Ø2.0 x 4.0	2.5 – 3.5	3.5 – 4.5
	NDR-S	6.0 x 2.5 x 2.5	6.0 – 7.0	7.5 – 8.5
	NDC-S	Ø3.0 x 7.0	7.5 – 8.5	9.0 – 10.0
	NDR-M	8.0 x 3.0 x 3.0	9.0 – 10.5	10.5 – 12.0
	NDC-M	Ø4.0 x 10.0	11.5 – 13.0	13.0 – 15.0
	NDR-L	19.0 x 4.0 x 4.0	16.0 – 19.5	18.5 – 22.0
	NDC-L	Ø8.0 x 15.0	24.0 – 28.0	27.5 – 32.0

Due to continual improvement, specifications are subject to change without notice

www.reed-sensor.com

20 January 2009

R2-F Low Profile SMD Reed Sensor

Low profile SMD Package, Normally Open

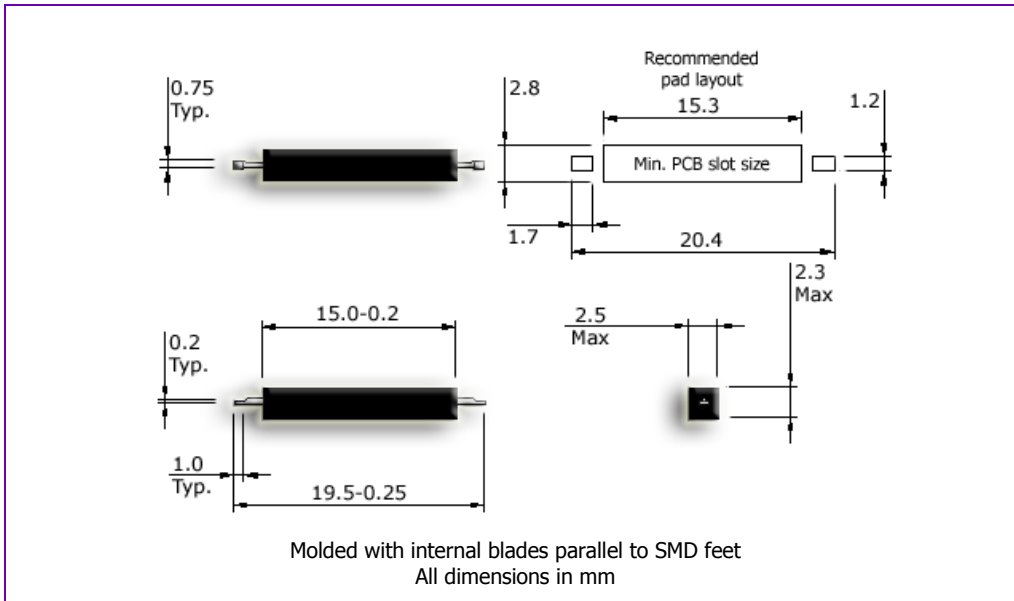

- ◆ Does not require power for operation
- ◆ Normally open (NO) form A contact
- ◆ Omni-polar device; actuates with either pole of magnet
- ◆ Molded with internal blades parallel to SMD feet
- ◆ Packed in tape and reels conforming to IEC-60286-3 norms
- ◆ Lead (Pb) free and RoHS compliant

Applications

This reed sensor is suitable for use in the following applications and many others: cellular phones and PDAs, weather proof electronics, fluid tank cap sensing, hands free kits...

Specification

Contact Form		A
Contact Rating (max)	W / VA	10
Switching Current (max)	A	0.5
Carry Current (max)	A	1.5
Switching Voltage (max)	V _{DC}	180
Breakdown Voltage (min)	V _{DC}	200
Initial Contact Resistance (max)	mΩ	150
Operating Temperature	°C	-40 to +140
Shock Resistance (½Sin wave for 11ms)	g	30
Vibration Resistance (10-2000Hz)	g	20

Ordering Code

R2-F-(Operate AT Code)-(Packing Code)

OAT Code	*Before	*After	Packing Code	
1	10 – 15	13 – 23	L	Plastic Box (500)
2	15 – 20	20 – 30	G	Tape (2500)
3	20 – 25	27 – 37		

*Indicate Operate AT band before and after modification of leads

Example

R2-F-1-G denotes 10-15 operate AT packed in taped spools.

Due to continual improvement, specifications are subject to change without notice

www.reed-sensor.com

1 February 2008

R2-S and R2-F Packing

Tape and reel specifications

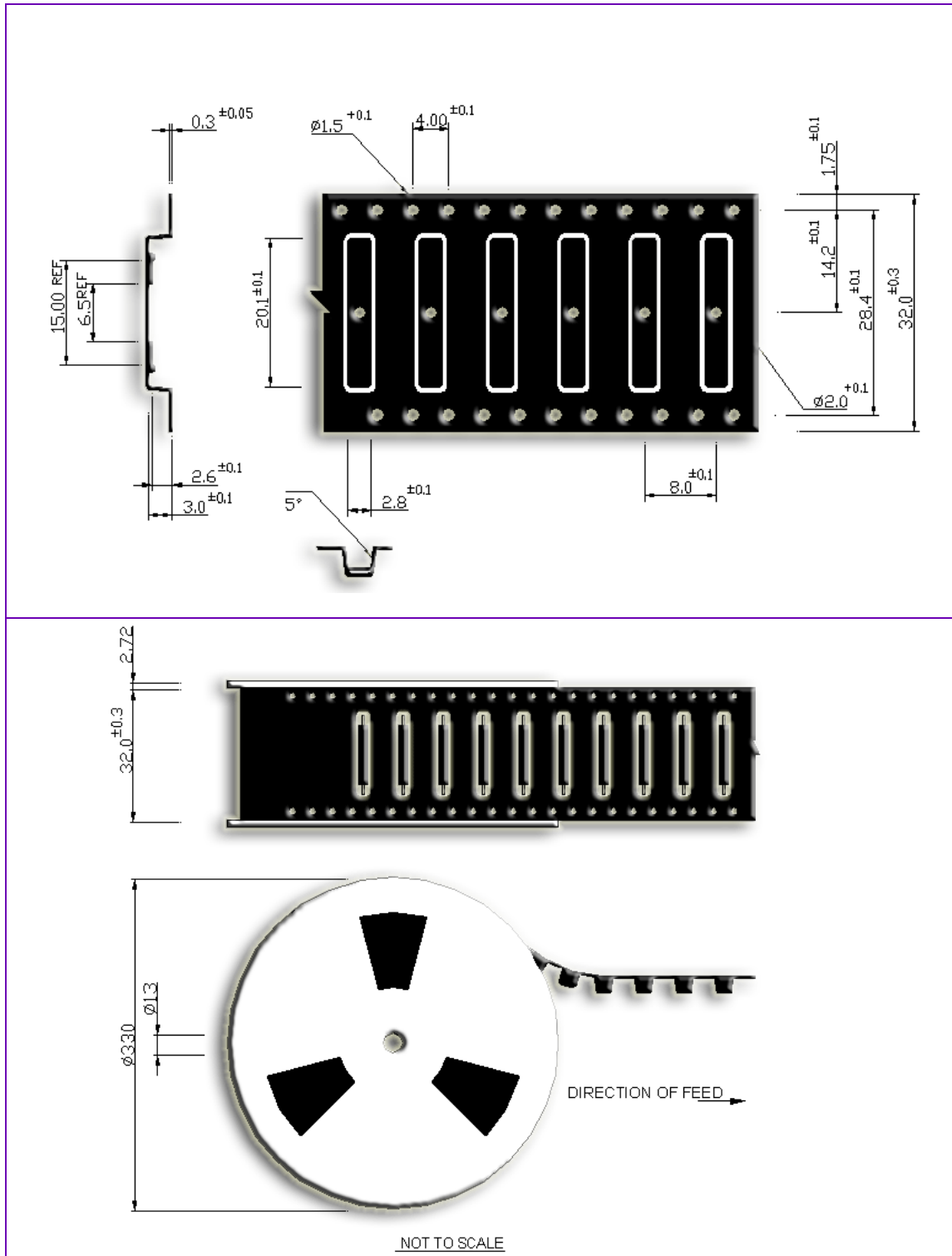

Tape and reel conform to IEC 60286-3 standards
40-80 g pull-force will be required to peel cover-tape
2500 sensors will be packed in one reel

Due to continual improvement, specifications are subject to change without notice

www.reed-sensor.com

11 December 2002

R2B-S NC SMD Reed Sensor

SMD Package, Form B, Normally closed

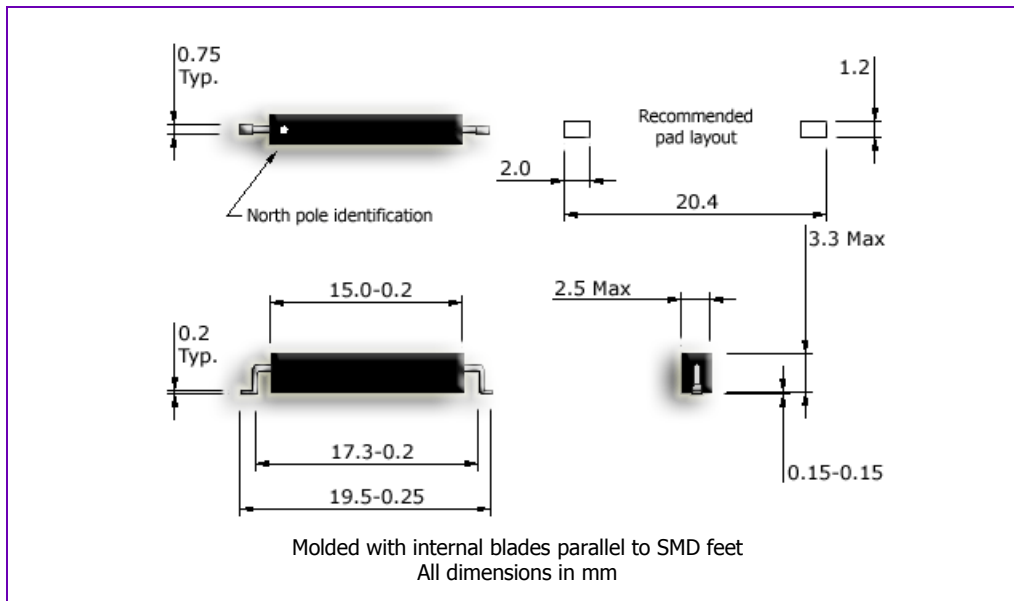

- ◆ Does not require power for operation
- ◆ Normally closed (NC) form B contact
- ◆ Polarity sensitive
- ◆ Molded with internal blades parallel to SMD feet
- ◆ Packed in tape and reels conforming to IEC-60286-3 norms
- ◆ Lead (Pb) free and RoHS compliant

🔧 Applications

This reed sensor is suitable for use in the following applications and many others: telephone hook switches, fluid tank cap sensing, emergency lamps...

📊 Specification

Contact Form		B
Contact Rating (max)	W / VA	10
Switching Current (max)	A	0.5
Carry Current (max)	A	1.5
Switching Voltage (max)	V _{DC}	180
Breakdown Voltage (min)	V _{DC}	200
Initial Contact Resistance (max)	mΩ	150
Operating Temperature	°C	-20 to +100
Shock Resistance (½Sin wave for 11ms)	g	30
Vibration Resistance (10-2000Hz)	g	20

📦 Ordering Code

R2B-S-(Release AT Code)

RAT Code	*Before	*After	Re-closure (min)
0	05 – 10	10 – 22	70
1	10 – 15	20 – 32	100
2	15 – 20	30 – 42	130

*Indicate Operate AT band before and after modification of leads

🔧 Example

R2B-S-1 denotes 10-15 release AT.

Due to continual improvement, specifications are subject to change without notice

www.reed-sensor.com

1 February 2008

R2B-S NC SMD Reed Sensor

Actuation Distances

Release, operate and re-closure distances for the R2B-S normally closed SMD reed sensor in the three standard AT bands when actuated (as shown in the sketches) with NdFeB standard magnets is shown below. All distances given are in mm with tolerances of ± 0.5 mm. Although some of the AT band / magnet combinations will produce similar actuating distances, selecting the right AT band and magnet for an application is important and can be done by going through our AT band FAQ and our magnet selection guide.

R2B-S-0 (05-10 AT)

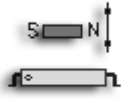
Actuation Sketch	Magnet	Dimensions	Release Distance	Operate Distance	Re-closure Zone
	NDR-T	4.0 x 1.5 x 1.5	3.5 – 7.0	4.0 – 7.5	< 0.5
	NDC-T	∅2.0 x 4.0	4.0 – 7.5	5.0 – 8.0	< 1.0
	NDR-S	6.0 x 2.5 x 2.5	8.0 – 12.5	10.0 – 14.0	< 3.5
	NDC-S	∅3.0 x 7.0	10.0 – 15.0	11.0 – 16.0	< 4.5
	NDR-M	8.0 x 3.0 x 3.0	11.5 – 17.5	13.0 – 19.0	< 5.5
	NDC-M	∅4.0 x 10.0	15.0 – 22.0	17.0 – 23.0	< 7.0
	NDR-L	19.0 x 4.0 x 4.0	21.0 – 31.5	23.5 – 34.0	< 8.0
	NDC-L	∅8.0 x 15.0	30.0 – 45.0	34.0 – 48.0	< 15.0

R2B-S-1 (10-15 AT)

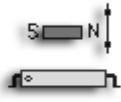
Actuation Sketch	Magnet	Dimensions	Release Distance	Operate Distance	Re-closure Zone
	NDR-T	4.0 x 1.5 x 1.5	2.0 – 4.0	2.5 – 4.5	< 0.5
	NDC-T	∅2.0 x 4.0	2.5 – 5.0	3.0 – 5.5	< 1.0
	NDR-S	6.0 x 2.5 x 2.5	6.5 – 9.0	7.0 – 10.0	< 3.0
	NDC-S	∅3.0 x 7.0	8.0 – 10.5	9.0 – 11.0	< 3.5
	NDR-M	8.0 x 3.0 x 3.0	9.5 – 12.5	10.0 – 13.5	< 4.5
	NDC-M	∅4.0 x 10.0	12.0 – 16.0	13.0 – 17.0	< 5.0
	NDR-L	19.0 x 4.0 x 4.0	17.0 – 21.5	18.0 – 23.0	< 7.0
	NDC-L	∅8.0 x 15.0	26.0 – 32.0	27.0 – 33.0	< 12.0

R2B-S-2 (15-20 AT)

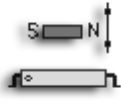
Actuation Sketch	Magnet	Dimensions	Release Distance	Operate Distance	Re-closure Zone
	NDR-T	4.0 x 1.5 x 1.5	1.5 – 2.5	2.0 – 3.0	< 0.5
	NDC-T	∅2.0 x 4.0	2.0 – 3.0	2.5 – 3.5	< 1.0
	NDR-S	6.0 x 2.5 x 2.5	5.0 – 7.0	5.5 – 8.0	< 2.5
	NDC-S	∅3.0 x 7.0	6.5 – 8.5	7.0 – 9.5	< 3.0
	NDR-M	8.0 x 3.0 x 3.0	8.0 – 10.0	8.5 – 11.0	< 4.0
	NDC-M	∅4.0 x 10.0	10.0 – 12.5	10.5 – 14.0	< 5.0
	NDR-L	19.0 x 4.0 x 4.0	14.5 – 18.0	15.0 – 19.0	< 6.0
	NDC-L	∅8.0 x 15.0	22.0 – 26.5	22.5 – 28.5	< 10.0

Due to continual improvement, specifications are subject to change without notice

www.reed-sensor.com

20 January 2009

R2B-F NC Low Profile SMD Reed Sensor

Low profile SMD package, Form B, Normally closed

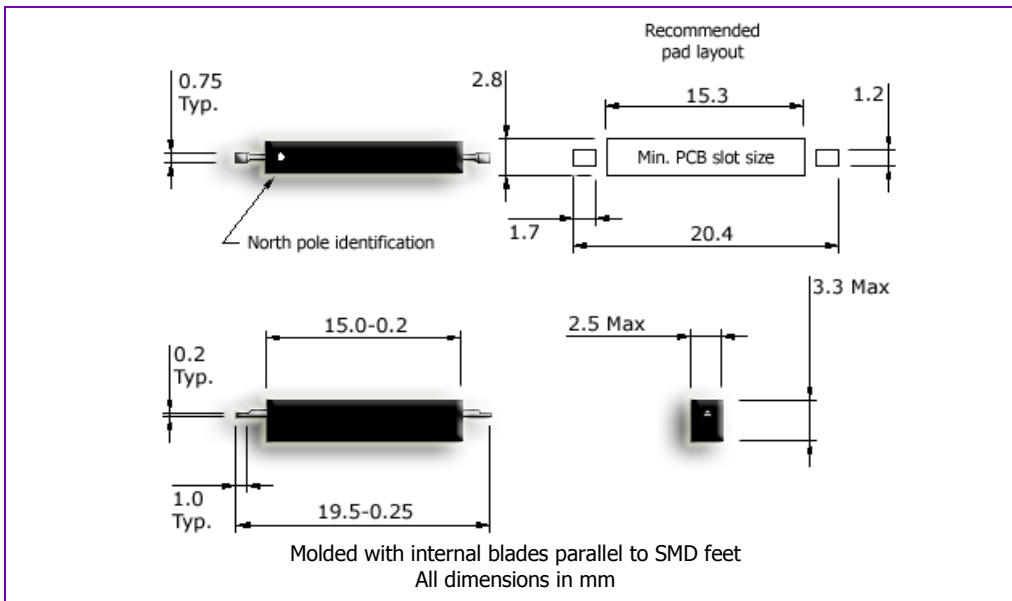

- ◆ Does not require power for operation
- ◆ Normally closed (NC) form B contact
- ◆ Polarity sensitive
- ◆ Molded with internal blades parallel to SMD feet
- ◆ Packed in tape and reels conforming to IEC-60286-3 norms
- ◆ Lead (Pb) free and RoHS compliant

🔧 Applications

This reed sensor is suitable for use in the following applications and many others: telephone hook switches, fluid tank cap sensing, emergency lamps...

📊 Specification

Contact Form		B
Contact Rating (max)	W / VA	10
Switching Current (max)	A	0.5
Carry Current (max)	A	1.5
Switching Voltage (max)	V _{DC}	180
Breakdown Voltage (min)	V _{DC}	200
Initial Contact Resistance (max)	mΩ	150
Operating Temperature	°C	-20 to +100
Shock Resistance (½Sin wave for 11ms)	g	30
Vibration Resistance (10-2000Hz)	g	20

📦 Ordering Code

R2B-F-(Release AT Code)

RAT Code	*Before	*After	Re-closure (min)
0	05 – 10	10 – 22	70
1	10 – 15	20 – 32	100
2	15 – 20	30 – 42	130

*Indicate Operate AT band before and after modification of leads

🔧 Example

R2B-F-1 denotes 10-15 release AT.

Due to continual improvement, specifications are subject to change without notice

www.reed-sensor.com

25 December 2006

R2E-S Latching SMD Reed Sensor

SMD Package, Form E, Latching

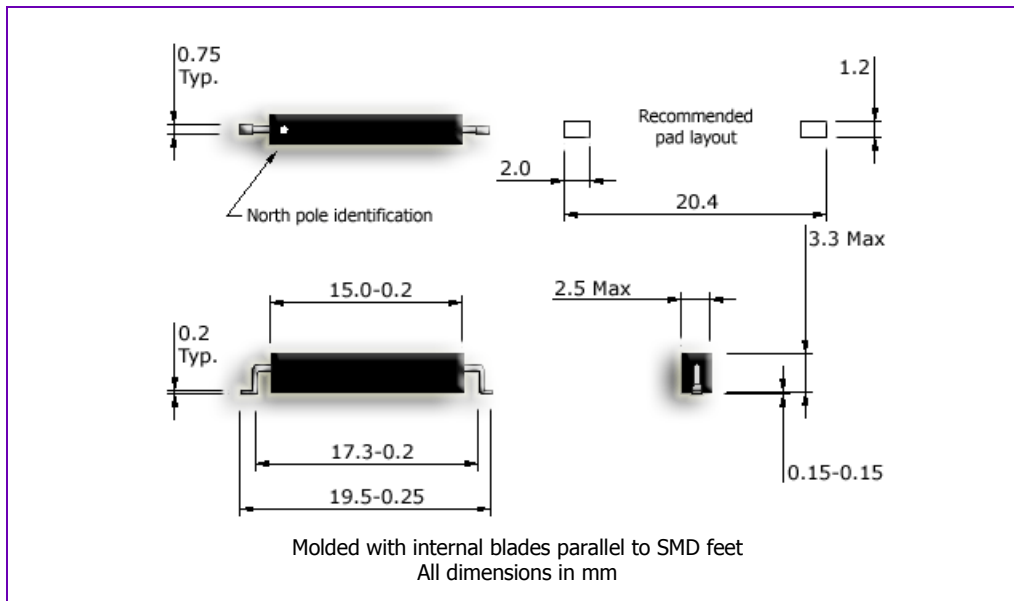

- ◆ Does not require power for operation
- ◆ Bi-stable, form E contact remembers state
- ◆ Polarity sensitive
- ◆ Molded with internal blades parallel to SMD feet
- ◆ Packed in tape and reels conforming to IEC-60286-3 norms
- ◆ Lead (Pb) free and RoHS compliant

Applications

This reed sensor is suitable for use in the following applications and many others: floor detection for elevators, lifts and hoists, level sensors...

Specification

Contact Form		E
Contact Rating (max)	W / VA	10
Switching Current (max)	A	0.5
Carry Current (max)	A	1.0
Switching Voltage (max)	V _{DC}	100
Breakdown Voltage (min)	V _{DC}	150
Initial Contact Resistance (max)	mΩ	150
Operating Temperature	°C	-20 to +100
Shock Resistance (½Sin wave for 11ms)	g	30
Vibration Resistance (10-2000Hz)	g	20

Ordering Code

R2E-S-(Operate AT Code)

OAT Code	
1	10 - 15

Please contact us for re-closure values

Example

R2E-S-1 denotes 10-15 operate and release AT.

Due to continual improvement, specifications are subject to change without notice

www.reed-sensor.com

25 December 2006

R2E-S Latching SMD Reed Sensor

Actuation Distances

Actuation distances (latch and un-latch) for the R2E-S bi-stable SMD reed sensor when actuated (as shown in the sketch) with NdFeB standard magnets is shown below. All distances given are in mm with tolerances of ± 0.5 mm. Although some of the AT band / magnet combinations will produce similar actuating distances, selecting the right AT band and magnet for an application is important and can be done by going through our AT band FAQ and our magnet selection guide.

R2E-S-1 (10-15 AT)

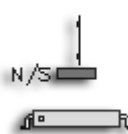
Actuation Sketch	Magnet	Dimensions	Latch/Un-Latch Distance
	NDR-T	4.0 x 1.5 x 1.5	7.0 - 9.0
	NDC-T	Ø2.0 x 4.0	8.0 - 10.0
	NDR-S	6.0 x 2.5 x 2.5	13.0 - 16.0
	NDC-S	Ø3.0 x 7.0	15.0 - 19.0
	NDR-M	8.0 x 3.0 x 3.0	18.0 - 21.0
	NDC-M	Ø4.0 x 10.0	22.0 - 26.0
	NDR-L	19.0 x 4.0 x 4.0	30.0 - 37.0
	NDC-L	Ø8.0 x 15.0	43.0 - 51.0

Due to continual improvement, specifications are subject to change without notice

www.reed-sensor.com

31 July 2008

R2E-F Latching Low Profile SMD Reed Sensor

Low profile SMD package, Form E, Latching

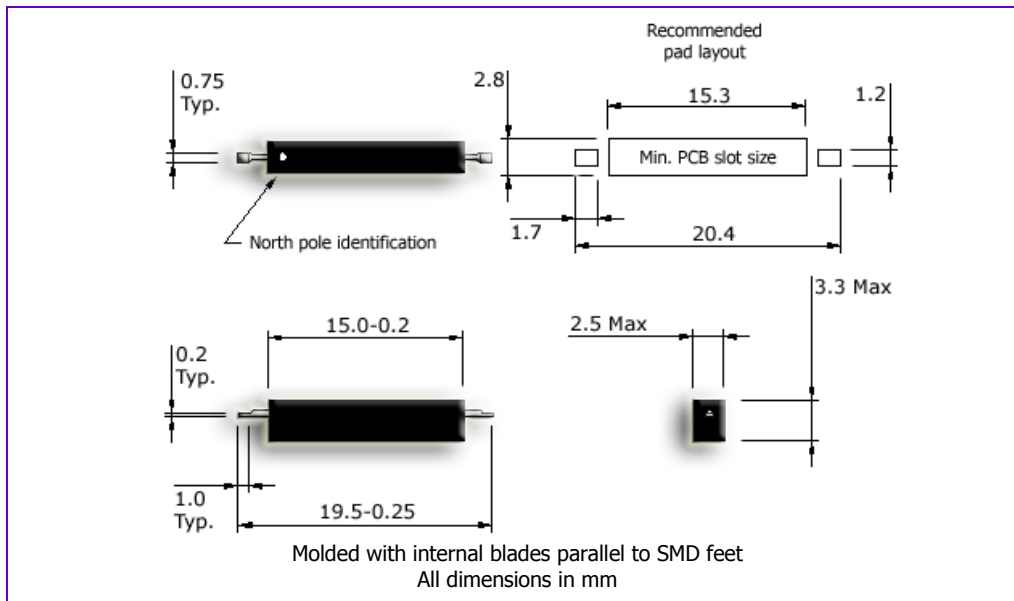

- ◆ Does not require power for operation
- ◆ Bi-stable, form E contact remembers state
- ◆ Polarity sensitive
- ◆ Molded with internal blades parallel to SMD feet
- ◆ Packed in tape and reels conforming to IEC-60286-3 norms
- ◆ Lead (Pb) free and RoHS compliant

🔧 Applications

This reed sensor is suitable for use in the following applications and many others: floor detection for elevators, lifts and hoists, level sensors...

📊 Specification

Contact Form		E
Contact Rating (max)	W / VA	10
Switching Current (max)	A	0.5
Carry Current (max)	A	1.0
Switching Voltage (max)	V _{DC}	100
Breakdown Voltage (min)	V _{DC}	150
Initial Contact Resistance (max)	mΩ	150
Operating Temperature	°C	-20 to +100
Shock Resistance (½Sin wave for 11ms)	g	30
Vibration Resistance (10-2000Hz)	g	20

📦 Ordering Code

R2E-F-(Operate AT Code)

OAT Code	
1	10 – 15

Please contact us for re-closure values

📝 Example

R2E-F-1 denotes 10-15 operate and release AT.

Due to continual improvement, specifications are subject to change without notice

www.reed-sensor.com

25 December 2006

R2B and R2E Packing

Tape and reel specifications

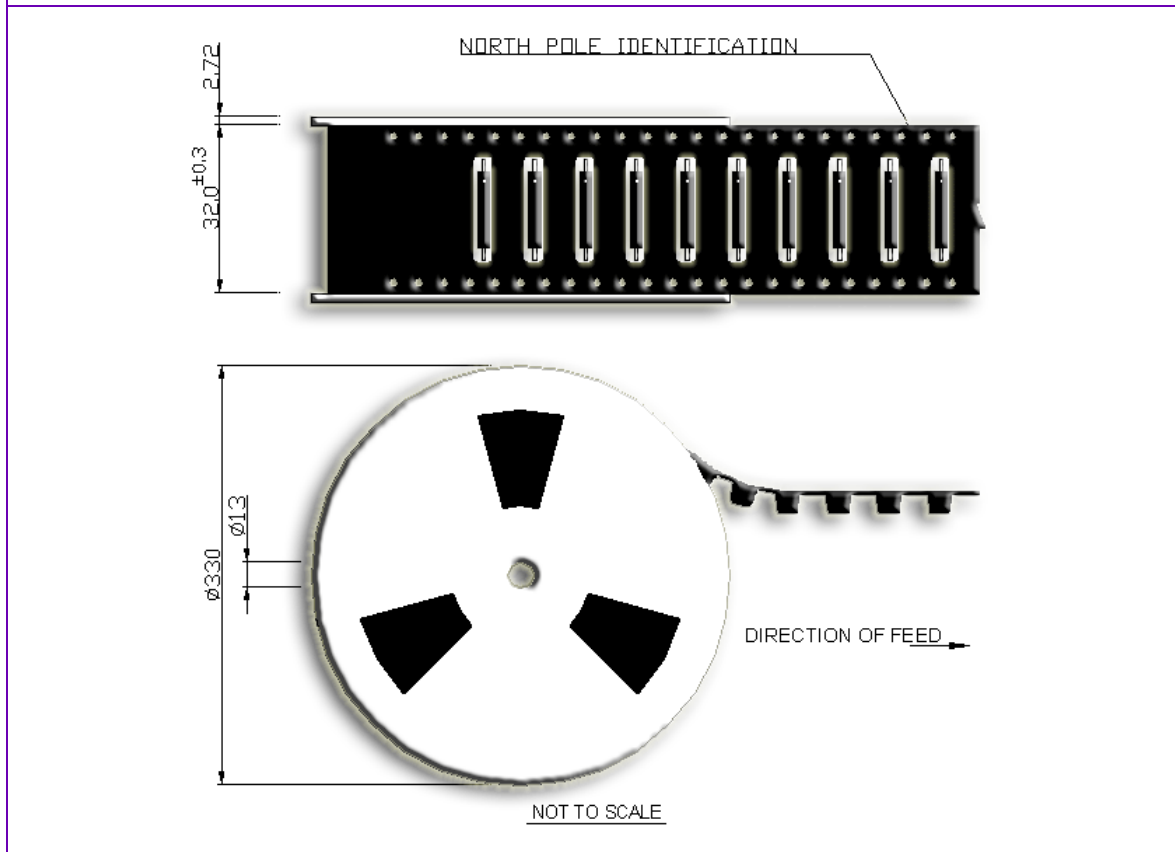
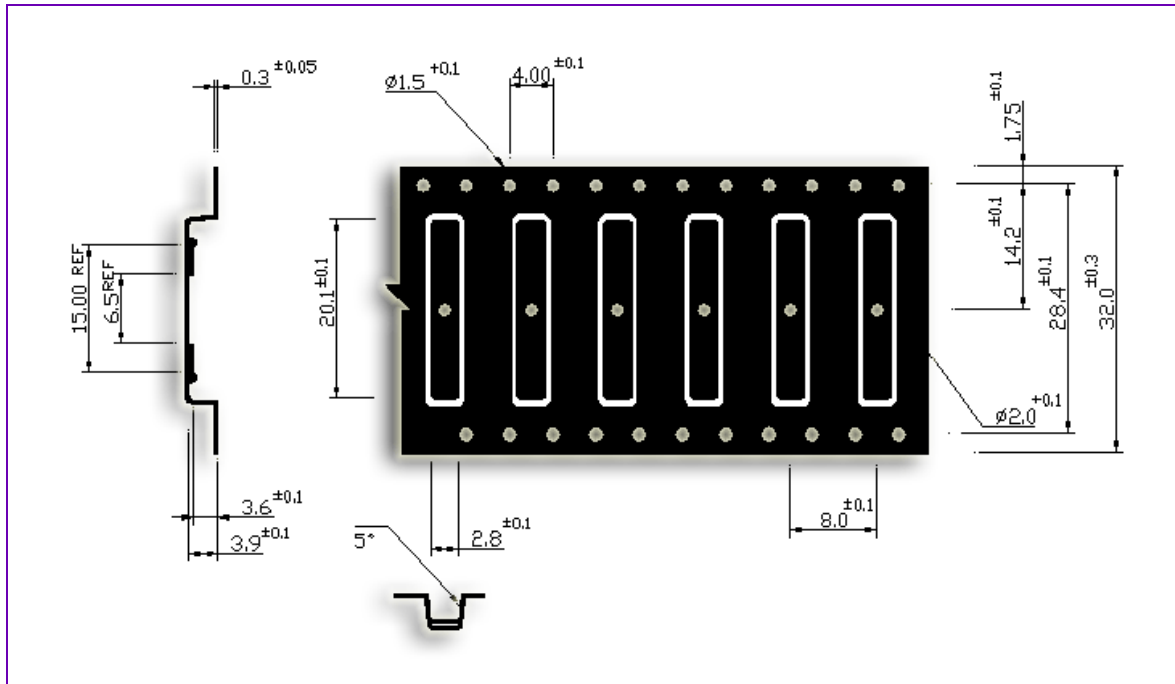

Tape and reel conform to IEC 60286-3 standards
40-80 g pull-force will be required to peel cover-tape
2000 sensors will be packed in one reel

Due to continual improvement, specifications are subject to change without notice

www.reed-sensor.com

6 December 2002

MK Reed Sensor with integrated resistor

2.54 mm pitch SIP Package

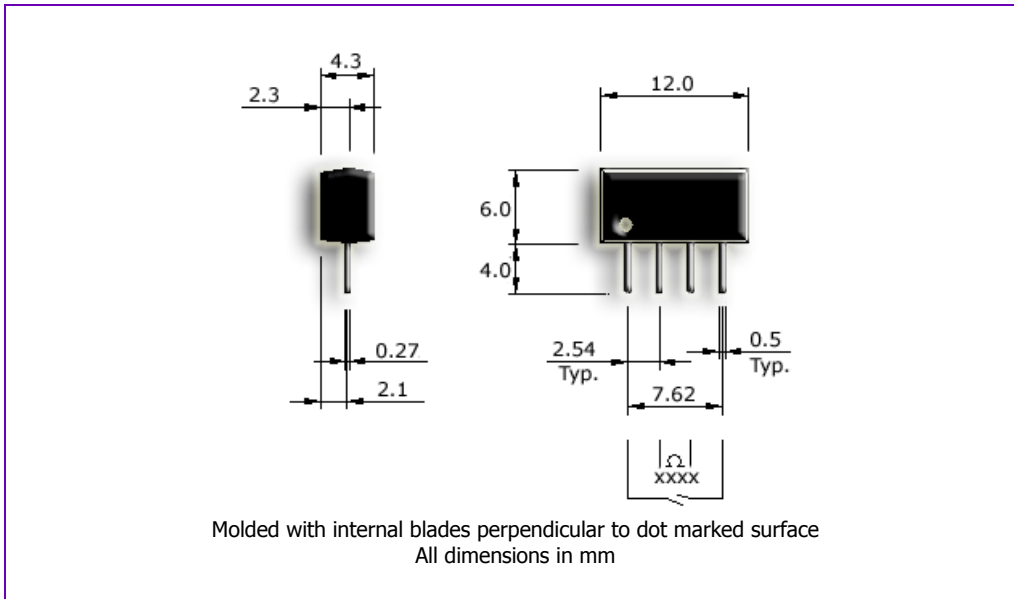

- ◆ Does not require power for operation
- ◆ Normally open (NO) form A contact
- ◆ Omni-polar device; actuates with either pole of magnet
- ◆ Various wattages and resistor values
- ◆ Ideal for level sensing applications
- ◆ Lead (Pb) free and RoHS compliant

Applications

This reed sensor is suitable for use in the following applications and many others: fluid level sensing, contact protection, resistance matrixes...

Specification

Contact Form		A
Contact Rating (max)	W / VA	10
Switching Current (max)	A	0.5
Carry Current (max)	A	0.75
Switching Voltage (max)	V _{DC}	100
Breakdown Voltage (min)	V _{DC}	150
Initial Contact Resistance (max)	mΩ	150
Operating Temperature	°C	-40 to +140
Shock Resistance (½Sin wave for 11ms)	g	30
Vibration Resistance (10-2000Hz)	g	20

Ordering Code

MK-(Resistor Value)-(Operate AT Code)

OAT Code	
1	10 – 15
2	15 – 20

Resistor value in ordering code refers to standard integrated resistor (1/8 W, 1% tolerance)

Example

MK-1-0180 denotes 10-15 operate AT with an integrated 180Ω resistor.

Due to continual improvement, specifications are subject to change without notice

www.reed-sensor.com

25 December 2006

MK Reed Sensor with integrated resistor

Actuation Distances

Operate and release distances for the MK-xxxx reed sensor in the two standard AT bands when actuated (as shown in the sketches) with NdFeB standard magnets is shown below. All distances given are in mm with tolerances of $\pm 0.5\text{mm}$. Distances given will vary if the reed sensor leads are cropped after soldering. Although some of the AT band / magnet combinations will produce similar actuating distances, selecting the right AT band and magnet for an application is important and can be done by going through our AT band FAQ and our magnet selection guide.

MK-xxxx-1 (10-15 AT)

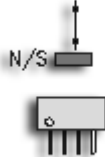
Actuation Sketch	Magnet	Dimensions	Operate Distance	Release Distance
	NDR-T	4.0 x 1.5 x 1.5	1.0 - 2.5	1.5 - 3.0
	NDC-T	$\varnothing 2.0 \times 4.0$	1.5 - 3.0	2.0 - 3.5
	NDR-S	6.0 x 2.5 x 2.5	4.0 - 7.0	5.0 - 7.5
	NDC-S	$\varnothing 3.0 \times 7.0$	5.5 - 8.0	6.0 - 8.5
	NDR-M	8.0 x 3.0 x 3.0	7.0 - 10.0	7.5 - 10.5
	NDC-M	$\varnothing 4.0 \times 10.0$	8.0 - 11.5	8.5 - 12.0
	NDR-L	19.0 x 4.0 x 4.0	12.0 - 17.0	13.0 - 18.0
	NDC-L	$\varnothing 8.0 \times 15.0$	19.0 - 25.0	20.0 - 26.0

MK-xxxx-2 (15-20 AT)

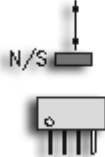
Actuation Sketch	Magnet	Dimensions	Operate Distance	Release Distance
	NDR-T	4.0 x 1.5 x 1.5	0.0 - 1.0	1.0 - 1.5
	NDC-T	$\varnothing 2.0 \times 4.0$	0.0 - 1.5	1.5 - 2.0
	NDR-S	6.0 x 2.5 x 2.5	3.5 - 4.5	4.0 - 5.5
	NDC-S	$\varnothing 3.0 \times 7.0$	4.5 - 5.5	5.0 - 6.5
	NDR-M	8.0 x 3.0 x 3.0	5.5 - 7.0	6.5 - 7.5
	NDC-M	$\varnothing 4.0 \times 10.0$	6.5 - 8.0	7.5 - 8.5
	NDR-L	19.0 x 4.0 x 4.0	10.0 - 12.0	12.0 - 13.0
	NDC-L	$\varnothing 8.0 \times 15.0$	16.5 - 19.0	18.0 - 20.0

Due to continual improvement, specifications are subject to change without notice

www.reed-sensor.com

25 December 2006

MS-104 Ultra-miniature Reed Sensor

10.16 mm PCB mounting pitch

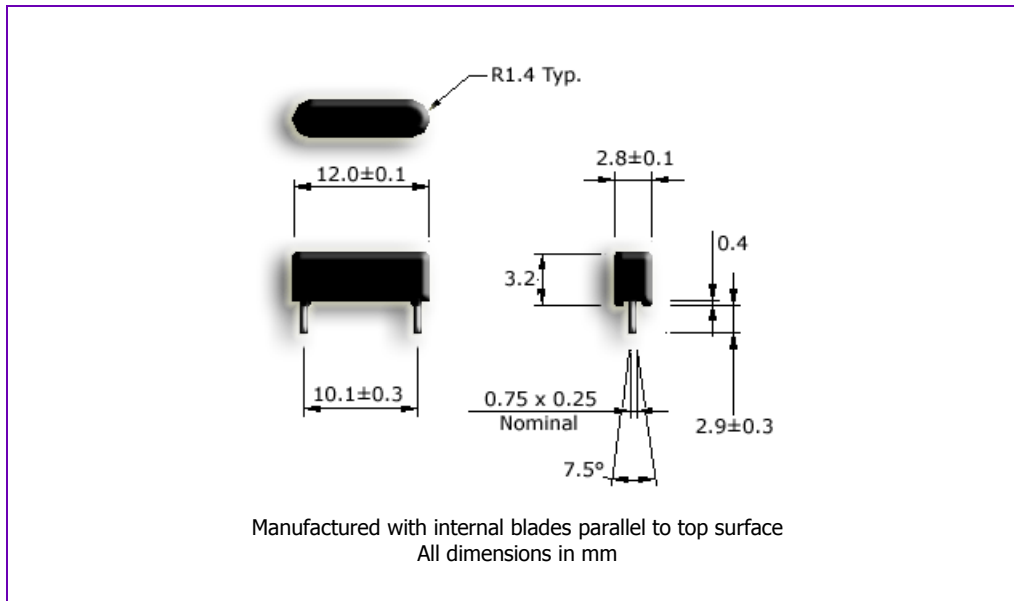

- ◆ Does not require power for operation
- ◆ Normally open (NO) form A contact
- ◆ Omni-polar device; actuates with either pole of magnet
- ◆ Lead (Pb) free and RoHS compliant

Applications

This reed sensor is suitable for use in the following applications and many others: telephone hook switches, detergent level sensing in washing machines, electric tooth brushes, sewing machine pedals, fluid tank cap sensing, two wheeler side stand, fluid level sensing, automobiles with electronic keys, survival rafts and ELTs, hands free kits, fuel pumps, pedometers...

Specification

Contact Form		A
Contact Rating (max)	W / VA	10.0
Switching Current (max)	A	0.5
Carry Current (max)	A	0.5
Switching Voltage (max)	V _{DC}	100
Breakdown Voltage (min)	V _{DC}	150
Initial Contact Resistance (max)	mΩ	200
Operating Temperature	°C	-40 to +100
Shock Resistance (½Sin wave for 11ms)	g	30
Vibration Resistance (10-2000Hz)	g	20

Ordering Code

MS-104-(Operate AT Code)

OAT Code	
1	10 - 15
2	15 - 20
3	20 - 25

Cropping the leads will increase OAT and RAT

Example

MS-104-3 denotes 20-25 operate AT.

Due to continual improvement, specifications are subject to change without notice

www.reed-sensor.com

25 December 2006

MS-104 Ultra-miniature Reed Sensor

Actuation Distances

Operate and release distances for the MS-104 reed sensor in the three standard AT bands when actuated (as shown in the sketches) with NdFeB standard magnets is shown below. All distances given are in mm with tolerances of $\pm 0.5\text{mm}$. Distances given will vary if the reed sensor leads are cropped after soldering. Although some of the AT band / magnet combinations will produce similar actuating distances, selecting the right AT band and magnet for an application is important and can be done by going through our AT band FAQ and our magnet selection guide.

MS-104-1 (10-15 AT)

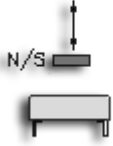
Actuation Sketch	Magnet	Dimensions	Operate Distance	Release Distance
	NDR-T	4.0 x 1.5 x 1.5	2.0 - 3.0	2.5 - 3.5
	NDC-T	Ø2.0 x 4.0	3.0 - 3.5	3.5 - 4.0
	NDR-S	6.0 x 2.5 x 2.5	6.0 - 7.0	6.5 - 7.5
	NDC-S	Ø3.0 x 7.0	7.5 - 8.5	8.0 - 9.0
	NDR-M	8.0 x 3.0 x 3.0	8.5 - 10.0	9.5 - 11.0
	NDC-M	Ø4.0 x 10.0	10.0 - 12.0	11.5 - 13.0
	NDR-L	19.0 x 4.0 x 4.0	15.0 - 17.5	16.5 - 19.0
	NDC-L	Ø8.0 x 15.0	24.5 - 27.0	26.5 - 29.0

MS-104-2 (15-20 AT)

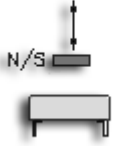
Actuation Sketch	Magnet	Dimensions	Operate Distance	Release Distance
	NDR-T	4.0 x 1.5 x 1.5	1.5 - 2.0	2.0 - 2.5
	NDC-T	Ø2.0 x 4.0	2.0 - 3.0	2.5 - 3.5
	NDR-S	6.0 x 2.5 x 2.5	5.0 - 6.0	5.5 - 6.5
	NDC-S	Ø3.0 x 7.0	6.0 - 7.5	6.5 - 8.0
	NDR-M	8.0 x 3.0 x 3.0	7.0 - 8.5	8.0 - 9.5
	NDC-M	Ø4.0 x 10.0	9.0 - 10.0	10.0 - 11.5
	NDR-L	19.0 x 4.0 x 4.0	13.0 - 15.0	14.5 - 16.5
	NDC-L	Ø8.0 x 15.0	21.0 - 24.5	23.0 - 26.5

MS-104-3 (20-25 AT)

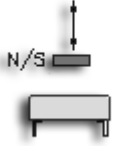
Actuation Sketch	Magnet	Dimensions	Operate Distance	Release Distance
	NDR-T	4.0 x 1.5 x 1.5	1.0 - 1.5	1.5 - 2.0
	NDC-T	Ø2.0 x 4.0	1.5 - 2.0	2.0 - 2.5
	NDR-S	6.0 x 2.5 x 2.5	4.5 - 5.0	5.0 - 5.5
	NDC-S	Ø3.0 x 7.0	5.0 - 6.0	6.0 - 6.5
	NDR-M	8.0 x 3.0 x 3.0	6.0 - 7.0	7.0 - 8.0
	NDC-M	Ø4.0 x 10.0	7.0 - 8.5	8.0 - 9.5
	NDR-L	19.0 x 4.0 x 4.0	12.0 - 13.0	13.5 - 14.5
	NDC-L	Ø8.0 x 15.0	20.0 - 21.0	22.0 - 23.0

Due to continual improvement, specifications are subject to change without notice

www.reed-sensor.com

30 September 2006

MS-105 Micro-miniature Reed Sensor

12.7 mm PCB mounting pitch

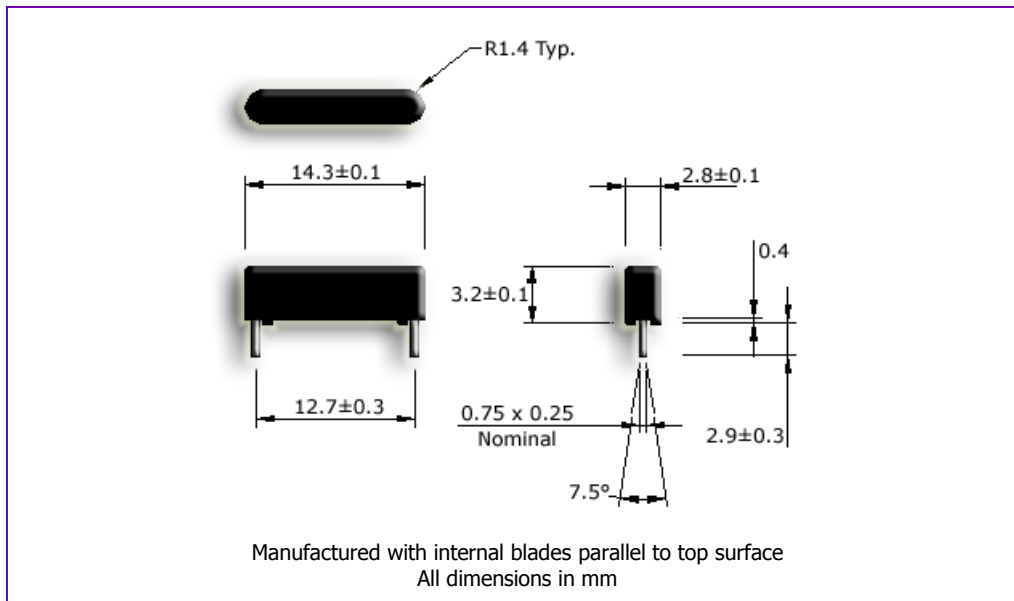

- ◆ Does not require power for operation
- ◆ Normally open (NO) form A contact
- ◆ Omni-polar device; actuates with either pole of magnet
- ◆ Lead (Pb) free and RoHS compliant

Applications

This reed sensor is suitable for use in the following applications and many others: telephone hook switches, detergent level sensing in washing machines, electric tooth brushes, sewing machine pedals, fluid tank cap sensing, two wheeler side stand, fluid level sensing, automobiles with electronic keys, survival rafts and ELTs, hands free kits, fuel pumps, pedometers...

Specification

Contact Form		A
Contact Rating (max)	W / VA	10.0
Switching Current (max)	A	0.5
Carry Current (max)	A	0.75
Switching Voltage (max)	V_{DC}	100
Breakdown Voltage (min)	V_{DC}	150
Initial Contact Resistance (max)	$m\Omega$	150
Operating Temperature	$^{\circ}C$	-40 to +100
Shock Resistance ($\frac{1}{2}$ Sin wave for 11ms)	g	30
Vibration Resistance (10-2000Hz)	g	20

Ordering Code

MS-105-(Operate AT Code)

OAT Code	
1	10 - 15
2	15 - 20
3	20 - 25

Cropping the leads will increase OAT and RAT

Example

MS-105-2 denotes 15-20 operate AT.

Due to continual improvement, specifications are subject to change without notice

www.reed-sensor.com

25 December 2006

MS-105 Micro-miniature Reed Sensor

Actuation Distances

Operate and release distances for the MS-105 reed sensor in the three standard AT bands when actuated (as shown in the sketches) with NdFeB standard magnets is shown below. All distances given are in mm with tolerances of $\pm 0.5\text{mm}$. Distances given will vary if the reed sensor leads are cropped after soldering. Although some of the AT band / magnet combinations will produce similar actuating distances, selecting the right AT band and magnet for an application is important and can be done by going through our AT band FAQ and our magnet selection guide.

MS-105-1 (10-15 AT)

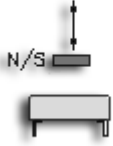
Actuation Sketch	Magnet	Dimensions	Operate Distance	Release Distance
	NDR-T	4.0 x 1.5 x 1.5	1.5 - 2.5	2.5 - 3.5
	NDC-T	$\varnothing 2.0 \times 4.0$	2.0 - 3.5	3.0 - 4.5
	NDR-S	6.0 x 2.5 x 2.5	6.5 - 8.0	7.5 - 8.5
	NDC-S	$\varnothing 3.0 \times 7.0$	8.0 - 9.5	8.5 - 10.0
	NDR-M	8.0 x 3.0 x 3.0	8.0 - 11.0	10.0 - 12.5
	NDC-M	$\varnothing 4.0 \times 10.0$	9.5 - 13.0	11.5 - 14.5
	NDR-L	19.0 x 4.0 x 4.0	15.5 - 19.5	17.0 - 22.0
	NDC-L	$\varnothing 8.0 \times 15.0$	24.5 - 30.0	27.0 - 33.0

MS-105-2 (15-20 AT)

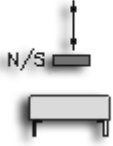
Actuation Sketch	Magnet	Dimensions	Operate Distance	Release Distance
	NDR-T	4.0 x 1.5 x 1.5	1.5 - 2.0	2.5 - 3.0
	NDC-T	$\varnothing 2.0 \times 4.0$	2.0 - 3.0	3.0 - 3.5
	NDR-S	6.0 x 2.5 x 2.5	6.0 - 6.5	7.0 - 7.5
	NDC-S	$\varnothing 3.0 \times 7.0$	7.0 - 8.0	8.5 - 9.0
	NDR-M	8.0 x 3.0 x 3.0	8.0 - 9.0	9.5 - 10.0
	NDC-M	$\varnothing 4.0 \times 10.0$	9.0 - 10.5	11.0 - 11.5
	NDR-L	19.0 x 4.0 x 4.0	14.5 - 15.5	17.0 - 19.0
	NDC-L	$\varnothing 8.0 \times 15.0$	22.5 - 25.0	27.0 - 29.0

MS-105-3 (20-25 AT)

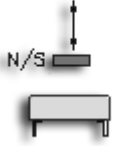
Actuation Sketch	Magnet	Dimensions	Operate Distance	Release Distance
	NDR-T	4.0 x 1.5 x 1.5	1.0 - 1.5	2.0 - 2.5
	NDC-T	$\varnothing 2.0 \times 4.0$	1.5 - 2.5	2.5 - 3.5
	NDR-S	6.0 x 2.5 x 2.5	5.0 - 6.0	6.5 - 7.0
	NDC-S	$\varnothing 3.0 \times 7.0$	6.0 - 6.5	7.5 - 8.5
	NDR-M	8.0 x 3.0 x 3.0	7.0 - 8.0	9.0 - 10.0
	NDC-M	$\varnothing 4.0 \times 10.0$	8.0 - 9.0	10.5 - 11.5
	NDR-L	19.0 x 4.0 x 4.0	12.5 - 14.5	16.0 - 18.0
	NDC-L	$\varnothing 8.0 \times 15.0$	20.5 - 23.0	25.0 - 27.5

Due to continual improvement, specifications are subject to change without notice

www.reed-sensor.com

30 September 2006

MS-106 Reduced-miniature Reed Sensor

15.24 mm PCB mounting pitch

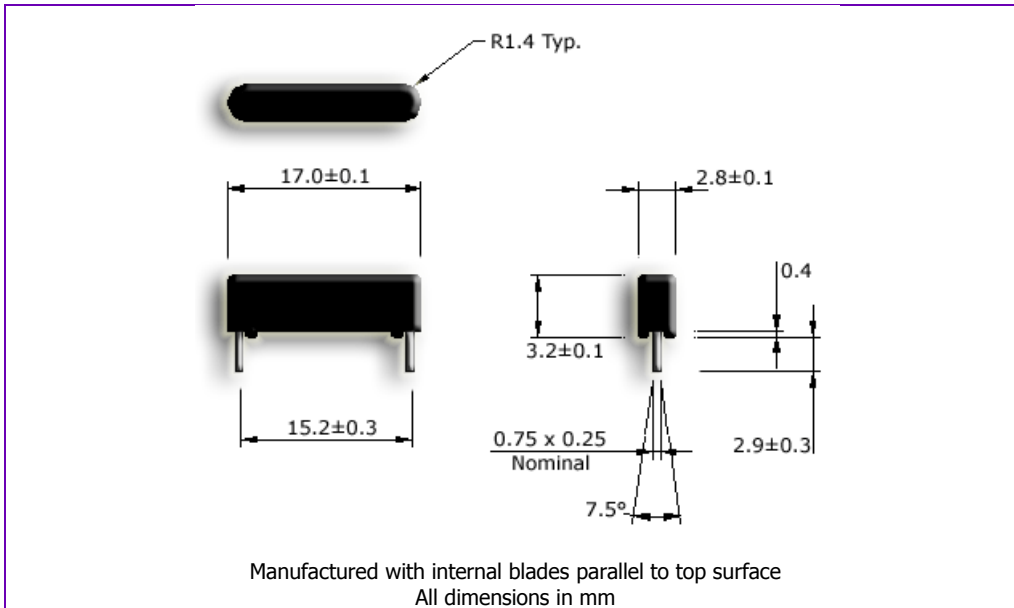

- ◆ Does not require power for operation
- ◆ Normally open (NO) form A contact
- ◆ Omni-polar device; actuates with either pole of magnet
- ◆ Lead (Pb) free and RoHS compliant

Applications

This reed sensor is suitable for use in the following applications and many others: telephone hook switches, detergent level sensing in washing machines, electric tooth brushes, sewing machine pedals, fluid tank cap sensing, two wheeler side stand, fluid level sensing, automobiles with electronic keys, survival rafts and ELTs, hands free kits, fuel pumps, pedometers...

Specification

Contact Form		A
Contact Rating (max)	W / VA	10.0
Switching Current (max)	A	0.5
Carry Current (max)	A	0.75
Switching Voltage (max)	V _{DC}	100
Breakdown Voltage (min)	V _{DC}	150
Initial Contact Resistance (max)	mΩ	150
Operating Temperature	°C	-40 to +100
Shock Resistance (½Sin wave for 11ms)	g	30
Vibration Resistance (10-2000Hz)	g	20

Ordering Code

MS-106-(Operate AT Code)

OAT Code	
1	10 - 15
2	15 - 20
3	20 - 25

Operate AT bands indicated above are for unmodified reed switch

Cropping the leads will increase OAT and RAT

Example

MS-106-1 denotes 10-15 operate AT.

Due to continual improvement, specifications are subject to change without notice

www.reed-sensor.com

25 December 2006

MS-106 Reduced-miniature Reed Sensor

Actuation Distances

Operate and release distances for the MS-106 reed sensor in the three standard AT bands when actuated (as shown in the sketches) with NdFeB standard magnets is shown below. All distances given are in mm with tolerances of $\pm 0.5\text{mm}$. Distances given will vary if the reed sensor leads are cropped after soldering. Although some of the AT band / magnet combinations will produce similar actuating distances, selecting the right AT band and magnet for an application is important and can be done by going through our AT band FAQ and our magnet selection guide.

MS-106-1 (10-15 AT)

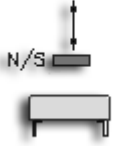
Actuation Sketch	Magnet	Dimensions	Operate Distance	Release Distance
	NDR-T	4.0 x 1.5 x 1.5	2.5 - 3.0	3.0 - 3.5
	NDC-T	$\varnothing 2.0 \times 4.0$	3.0 - 4.0	4.0 - 4.5
	NDR-S	6.0 x 2.5 x 2.5	7.0 - 8.5	8.0 - 9.5
	NDC-S	$\varnothing 3.0 \times 7.0$	8.5 - 10.5	10.0 - 12.0
	NDR-M	8.0 x 3.0 x 3.0	10.0 - 12.0	11.5 - 13.5
	NDC-M	$\varnothing 4.0 \times 10.0$	11.5 - 14.5	13.5 - 16.5
	NDR-L	19.0 x 4.0 x 4.0	17.5 - 21.5	20.5 - 24.5
	NDC-L	$\varnothing 8.0 \times 15.0$	27.0 - 32.5	32.0 - 37.0

MS-106-2 (15-20 AT)

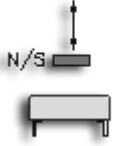
Actuation Sketch	Magnet	Dimensions	Operate Distance	Release Distance
	NDR-T	4.0 x 1.5 x 1.5	1.5 - 2.5	2.5 - 3.0
	NDC-T	$\varnothing 2.0 \times 4.0$	2.5 - 3.0	3.5 - 4.0
	NDR-S	6.0 x 2.5 x 2.5	6.0 - 7.0	7.5 - 9.0
	NDC-S	$\varnothing 3.0 \times 7.0$	7.0 - 8.5	9.0 - 10.5
	NDR-M	8.0 x 3.0 x 3.0	8.5 - 10.0	10.5 - 12.5
	NDC-M	$\varnothing 4.0 \times 10.0$	10.0 - 11.5	12.5 - 14.5
	NDR-L	19.0 x 4.0 x 4.0	15.0 - 18.0	19.0 - 21.5
	NDC-L	$\varnothing 8.0 \times 15.0$	24.0 - 28.0	29.0 - 33.0

MS-106-3 (20-25 AT)

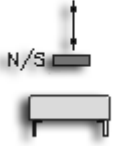
Actuation Sketch	Magnet	Dimensions	Operate Distance	Release Distance
	NDR-T	4.0 x 1.5 x 1.5	1.0 - 1.5	2.0 - 2.5
	NDC-T	$\varnothing 2.0 \times 4.0$	2.0 - 2.5	3.0 - 3.5
	NDR-S	6.0 x 2.5 x 2.5	5.0 - 5.5	7.0 - 7.5
	NDC-S	$\varnothing 3.0 \times 7.0$	6.5 - 7.0	8.5 - 9.0
	NDR-M	8.0 x 3.0 x 3.0	8.0 - 8.5	10.5 - 11.0
	NDC-M	$\varnothing 4.0 \times 10.0$	9.0 - 10.0	12.0 - 12.5
	NDR-L	19.0 x 4.0 x 4.0	14.0 - 16.0	18.0 - 19.0
	NDC-L	$\varnothing 8.0 \times 15.0$	23.0 - 24.0	28.0 - 29.0

Due to continual improvement, specifications are subject to change without notice

www.reed-sensor.com

30 September 2006

MS-107 Standard size Reed Sensor

17.78 mm PCB mounting pitch

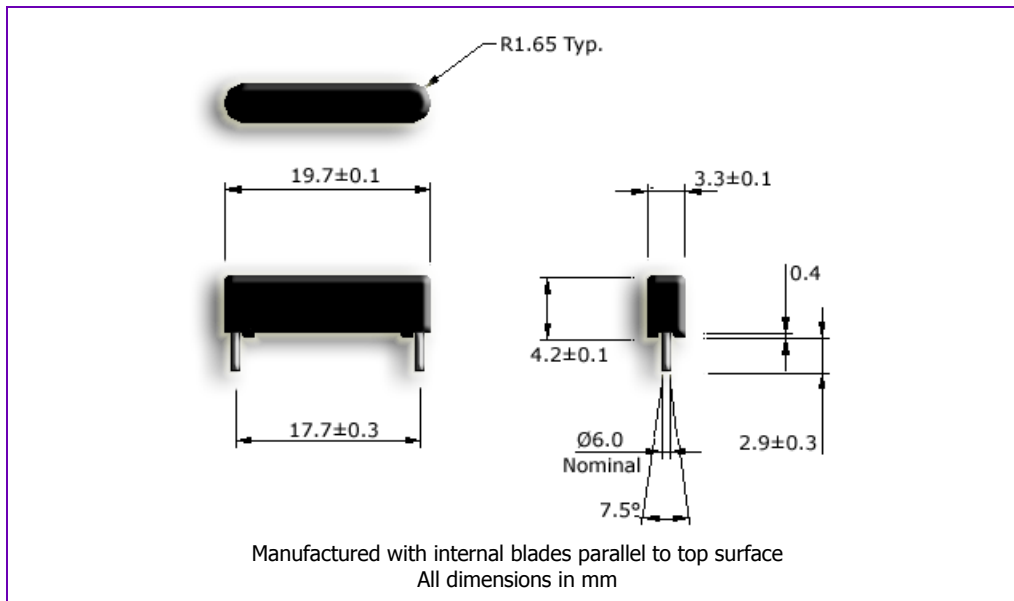

- ◆ Does not require power for operation
- ◆ Normally open (NO) form A contact
- ◆ Omni-polar device; actuates with either pole of magnet
- ◆ Lead (Pb) free and RoHS compliant

Applications

This reed sensor is suitable for use in the following applications and many others: microphones, radio transmitters, copier and scanner doors, coffee machines, rowing electronics, power switches in explosive areas...

Specification

Contact Form		A
Contact Rating (max)	W / VA	10
Switching Current (max)	A	0.5
Carry Current (max)	A	1.5
Switching Voltage (max)	V _{DC}	180
Breakdown Voltage (min)	V _{DC}	200
Initial Contact Resistance (max)	mΩ	150
Operating Temperature	°C	-40 to +100
Shock Resistance (½Sin wave for 11ms)	g	50
Vibration Resistance (10-2000Hz)	g	20

Ordering Code

MS-107-(Operate AT Code)

OAT Code	
1	10 - 15
2	15 - 20
3	20 - 25

Cropping the leads will increase OAT and RAT

Example

MS-107-1 denotes 10-15 operate AT.

Due to continual improvement, specifications are subject to change without notice

www.reed-sensor.com

25 December 2006

MS-108 Standard size Reed Sensor

20.32 mm PCB mounting pitch

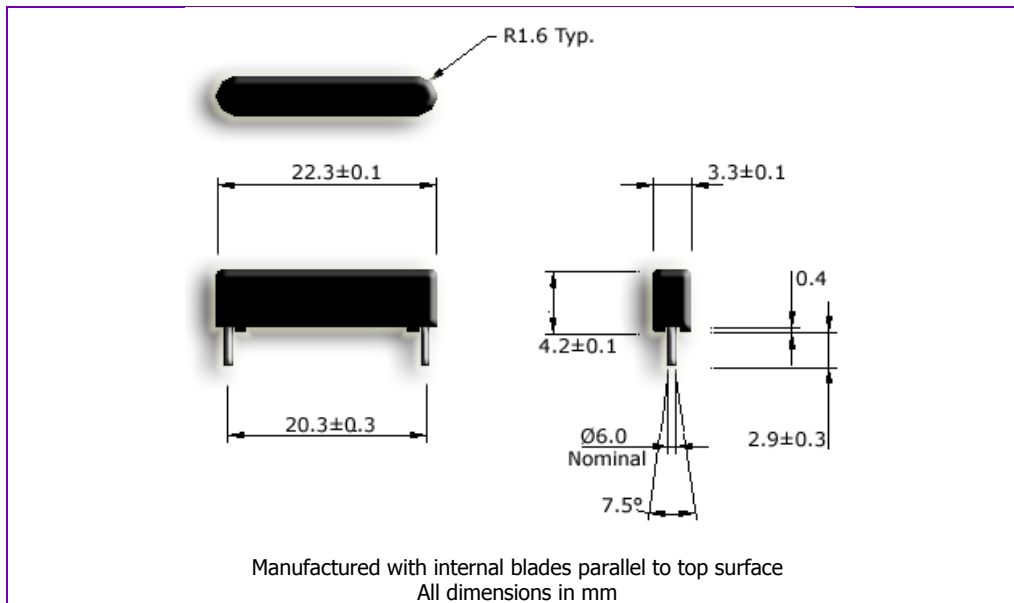

- ◆ Does not require power for operation
- ◆ Normally open (NO) form A contact
- ◆ Omni-polar device; actuates with either pole of magnet
- ◆ Lead (Pb) free and RoHS compliant

Applications

This reed sensor is suitable for use in the following applications and many others: microphones, radio transmitters, copier and scanner doors, coffee machines, rowing electronics, power switches in explosive areas...

Specification

Contact Form		A
Contact Rating (max)	W / VA	10
Switching Current (max)	A	0.5
Carry Current (max)	A	1.5
Switching Voltage (max)	V _{DC}	180
Breakdown Voltage (min)	V _{DC}	200
Initial Contact Resistance (max)	mΩ	150
Operating Temperature	°C	-40 to +100
Shock Resistance (½Sin wave for 11ms)	g	50
Vibration Resistance (10-2000Hz)	g	20

Ordering Code

MS-108-(Operate AT Code)

OAT Code	
1	10 - 15
2	15 - 20
3	20 - 25

Cropping the leads will increase OAT and RAT

Example

MS-108-2 denotes 15-20 operate AT.

Due to continual improvement, specifications are subject to change without notice

www.reed-sensor.com

25 December 2006

MS-108 Standard size Reed Sensor

Actuation Distances

Operate and release distances for the MS-108 reed sensor in the three standard AT bands when actuated (as shown in the sketches) with NdFeB standard magnets is shown below. All distances given are in mm with tolerances of $\pm 0.5\text{mm}$. Distances given will vary if the reed sensor leads are cropped after soldering. Although some of the AT band / magnet combinations will produce similar actuating distances, selecting the right AT band and magnet for an application is important and can be done by going through our AT band FAQ and our magnet selection guide.

MS-108-1 (10-15 AT)

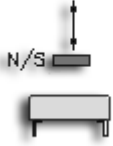
Actuation Sketch	Magnet	Dimensions	Operate Distance	Release Distance
	NDR-T	4.0 x 1.5 x 1.5	2.0 - 3.0	3.0 - 3.5
	NDC-T	$\varnothing 2.0 \times 4.0$	3.5 - 4.5	5.0 - 5.5
	NDR-S	6.0 x 2.5 x 2.5	7.5 - 10.0	10.0 - 11.5
	NDC-S	$\varnothing 3.0 \times 7.0$	9.5 - 11.5	12.0 - 13.0
	NDR-M	8.0 x 3.0 x 3.0	11.5 - 14.5	15.0 - 16.0
	NDC-M	$\varnothing 4.0 \times 10.0$	13.5 - 17.0	17.5 - 19.0
	NDR-L	19.0 x 4.0 x 4.0	21.5 - 25.5	26.5 - 28.5
	NDC-L	$\varnothing 8.0 \times 15.0$	32.0 - 38.0	41.0 - 42.0

MS-108-2 (15-20 AT)

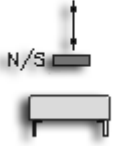
Actuation Sketch	Magnet	Dimensions	Operate Distance	Release Distance
	NDR-T	4.0 x 1.5 x 1.5	1.5 - 2.0	2.5 - 3.0
	NDC-T	$\varnothing 2.0 \times 4.0$	2.5 - 3.5	4.5 - 5.0
	NDR-S	6.0 x 2.5 x 2.5	6.5 - 7.5	9.5 - 10.0
	NDC-S	$\varnothing 3.0 \times 7.0$	8.0 - 9.5	11.0 - 12.0
	NDR-M	8.0 x 3.0 x 3.0	10.0 - 11.5	13.5 - 15.0
	NDC-M	$\varnothing 4.0 \times 10.0$	12.0 - 13.5	15.5 - 17.5
	NDR-L	19.0 x 4.0 x 4.0	18.0 - 21.5	24.5 - 26.5
	NDC-L	$\varnothing 8.0 \times 15.0$	28.0 - 32.0	37.0 - 41.0

MS-108-3 (20-25 AT)

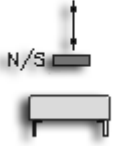
Actuation Sketch	Magnet	Dimensions	Operate Distance	Release Distance
	NDR-T	4.0 x 1.5 x 1.5	0.5 - 1.5	2.0 - 2.5
	NDC-T	$\varnothing 2.0 \times 4.0$	1.5 - 2.5	3.5 - 4.5
	NDR-S	6.0 x 2.5 x 2.5	5.5 - 6.5	8.5 - 9.5
	NDC-S	$\varnothing 3.0 \times 7.0$	7.0 - 8.0	10.5 - 11.5
	NDR-M	8.0 x 3.0 x 3.0	9.0 - 10.0	12.5 - 13.5
	NDC-M	$\varnothing 4.0 \times 10.0$	10.0 - 12.0	14.0 - 15.5
	NDR-L	19.0 x 4.0 x 4.0	16.0 - 18.0	22.5 - 24.5
	NDC-L	$\varnothing 8.0 \times 15.0$	25.0 - 28.0	34.0 - 37.0

Due to continual improvement, specifications are subject to change without notice

www.reed-sensor.com

30 September 2006

Test Coils

For Reed Switches and Sensors

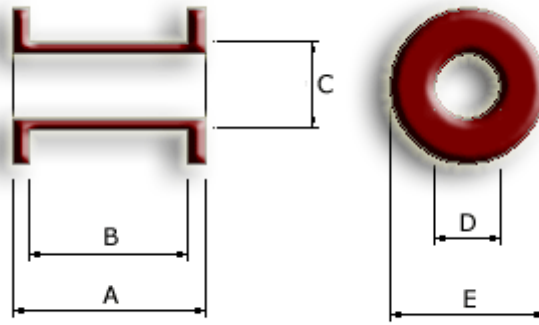

Cylindrical

Test Coil No.	717 102 001	717 102 002	717 102 003	717 102 004	717 102 005
A	53.3	21.0	12.0	27.8	19.0
B	50.8	19.0	10.0	25.4	15.0
C	7.6	4.3	3.3	8.7	3.7
D	5.6	3.4	2.3	2.4	2.9
E	14.1	7.7	11.0	17.2	11.0
Wire Diameter	0.090	0.050	0.060	0.100	0.071
Turns	10000	5000	5000	5000	5000
Coil Res. Ω	845	740	600	404	450

All dimensions in mm

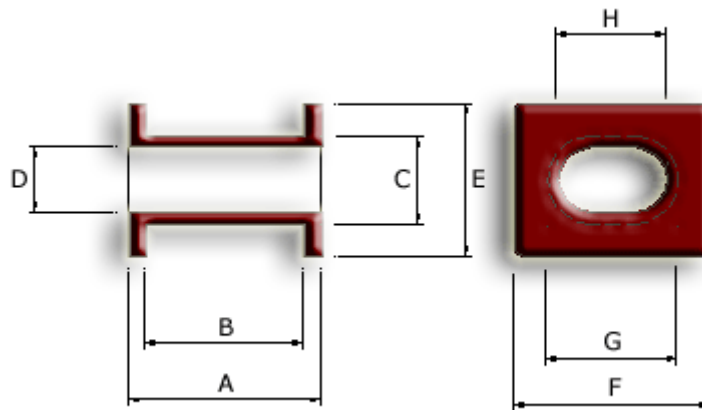

Rectangular

Test Coil	TCP 3001	TCP3002	TCP 3003	TCP 3004
A mm	13.5	23.3	42.5	42.5
B mm	7	19.7	36.5	36.5
C mm	8	6.8	14.8	15.8
D mm	6	6.2	13.8	13.8
E mm	14	14.8	25.0	25.0
F mm	18	20.6	28.6	35.6
G mm	12	12.2	14.6	22.8
H mm	10	11.6	13.6	20.8
Wire Diameter mm	0.05	0.08	0.15	0.15
Turns	5000	10000	5000	5000
Coil Resistance Ω	2000	1900	290	440

Due to continual improvement, specifications are subject to change without notice

www.reed-sensor.com

6 December 2004

Standard Magnets

For Reed Switches and Sensors

Cylindrical Magnets

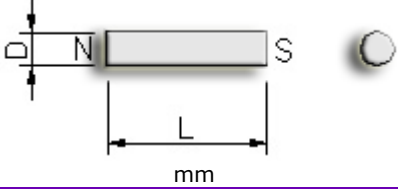
	Part Number	Material	D (mm)	L (mm)
	NDC-T	NdFeB:N35	2.0	4.0
	NDC-S	NdFeB:N35	3.0	7.0
	NDC-M	NdFeB:N35	4.0	10.0
	NDC-L	NdFeB:N35	8.0	15.0

Bar Magnets

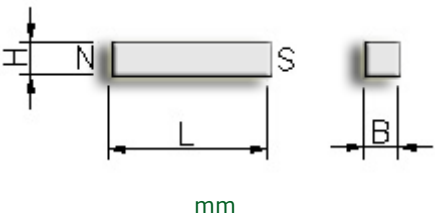
	Part Number	Material	L (mm)	B (mm)	H (mm)
	NDR-T	NdFeB:N35	4.0	1.5	1.5
	NDR-S	NdFeB:N35	6.0	2.5	2.5
	NDR-M	NdFeB:N35	8.0	3.0	3.0
	NDR-L	NdFeB:N35	19.0	4.0	4.0

Magnet Material Specifications

Magnet Type		Remanance	Coercivity		Energy Product max.	Operating Temperature
Composition	Code	Br (mT)	HcB (kA/m)	HcJ (kA/m)	BH (kJ/m ³)	(°C)
Ferrite	C8	385	235	242	27.8	300
AlNiCo	LNG37	1180	48	53	37	550
NdFeB	N35	1180	880	955	270	80
NdFeB	N35SH	1180	880	1353	270	120
SmCo	YX20	925	680	1595	160	300

Due to continual improvement, specifications are subject to change without notice

www.reed-sensor.com

30 August 2006

Restriction of Hazardous Substances

RoHS Compliance

In late 2002 the European Parliament approved two directives related to the reduction of electrical and electronic waste, namely the Waste Electrical and Electronic Equipment (WEEE) and Restriction of the use of certain Hazardous Substances (RoHS) Directives. The WEEE Directive aims to regulate the reuse, recycling and recovery of waste electrical and electronic equipment; the ultimate goal is to prevent the disposal of this waste.

In the RoHS Directive, the use of the aforementioned substances in most electrical and electronic equipment will be banned or severely restricted. The RoHS Directive calls for the elimination of these substances from most electronic equipment starting 1 July 2006. Our products are SGS certified for the RoHS compliant levels of Lead, Mercury, Cadmium and Hexavalent Chromium.

End-of-Life Vehicle (ELV)

End-of-Life Vehicle (ELV) regulations set limits for the following substances:

Lead
Mercury
Cadmium
Hexavalent Chromium

Restriction of Hazardous Substances (RoHS)

The Reduction of Hazardous Substances (RoHS) regulations set limits for the following substances:

Lead
Mercury
Cadmium
Hexavalent Chromium
Polybrominated Biphenyls (PBB)
Polybrominated Diphenyl Ethers (PBDE)

To certify to the above compliances, these substances must not be intentionally added to the product AND cannot exceed the following maximum allowable levels as a trace substance:

0.1% (1,000 ppm) for: Lead*, Mercury, Hexavalent Chromium, PBB and PBDE

0.01% (100 ppm) for: Cadmium

*Lead as an alloying element in copper alloys is allowed up to 4.0% (40,000 ppm); in steel up to 0.35% (3,500 ppm) is allowed; in aluminum alloys up to 0.40% (4,000 ppm) is allowed. These requirements must be applied at the homogeneous material level. Since RoHS compliance is a stricter standard than ELV compliance, parts that are RoHS compliant are also ELV compliant.

Due to continual improvement, specifications are subject to change without notice

www.reed-sensor.com

20 January 2009

Reed Sensor Usage Notes

Do's and Don'ts

Reed sensors are delicate products. Handle with extra care.
 Cropping of terminals will change the operate AT, release AT, and differential values.

Do's and Don'ts

✔ Do

When switching inductive or capacitive loads, use contact protection circuits. More information is available on our website.

Follow SMD soldering specifications. Exceeding these limits may permanently damage the sensors.

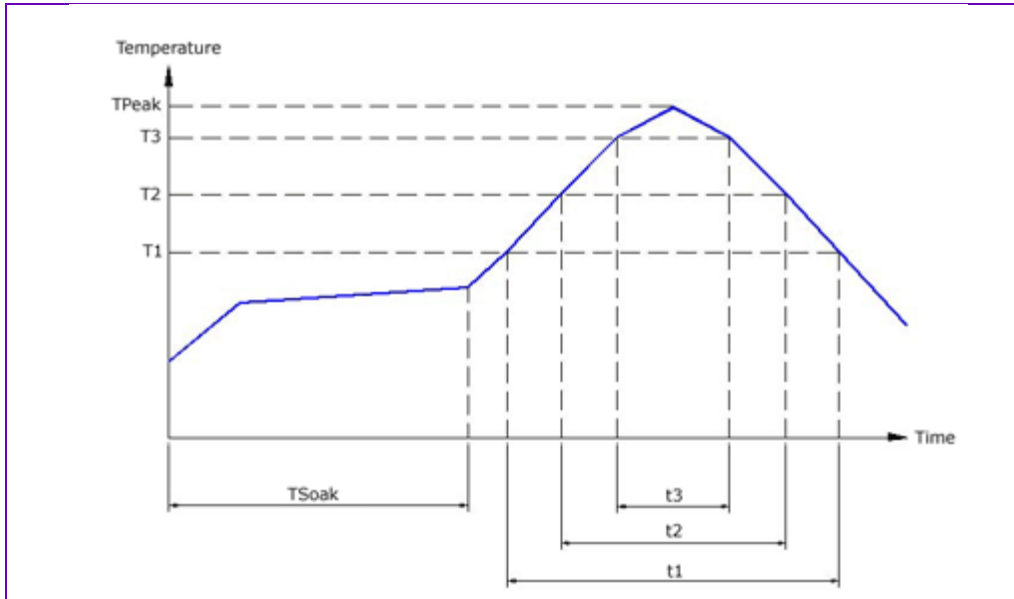

Preheat Temperature Gradient		+1 -4 °C/sec
Soak Time	T Soak	2-3 MIN
Time Above 100c		420 sec. Max.
Time Above 183c		120-180 sec.
Time Above 217c	t1 / T1	90 sec. Max.
Time Above 230c	t2 / T2	20-60 sec.
Time Above 250c	t3 / T3	10 sec. Max.
Peak Temperature	T Peak	255 -0/+5°C
Cooling Temperature Gradient		-6°C/sec.Max.

✘ Don't

Do not use ferro-magnetic mounting parts, screws, or other ferro-magnetic devices nearby. This will affect the sensitivity (AT). Even a magnetic field from a nearby motor may interfere with the working.

When manual soldering, do not subject the product to soldering tip dwell of more than 5 seconds. This may cause damage to the seals, change sensitivity, and reduce solderability.

Do not drop. Dropping or subjection to shock will permanently damage the contact or alter the magnetic sensitivity (AT).

Switching voltage, switching current, and contact rating should not exceed maximum limits stated in specification sheets.

Due to continual improvement, specifications are subject to change without notice

www.reed-sensor.com

12 February 2007